

MODULAR STEEL STORAGE SYSTEMS

SUPER 1/2/3

PATENTED BOLTLESS SHELVING

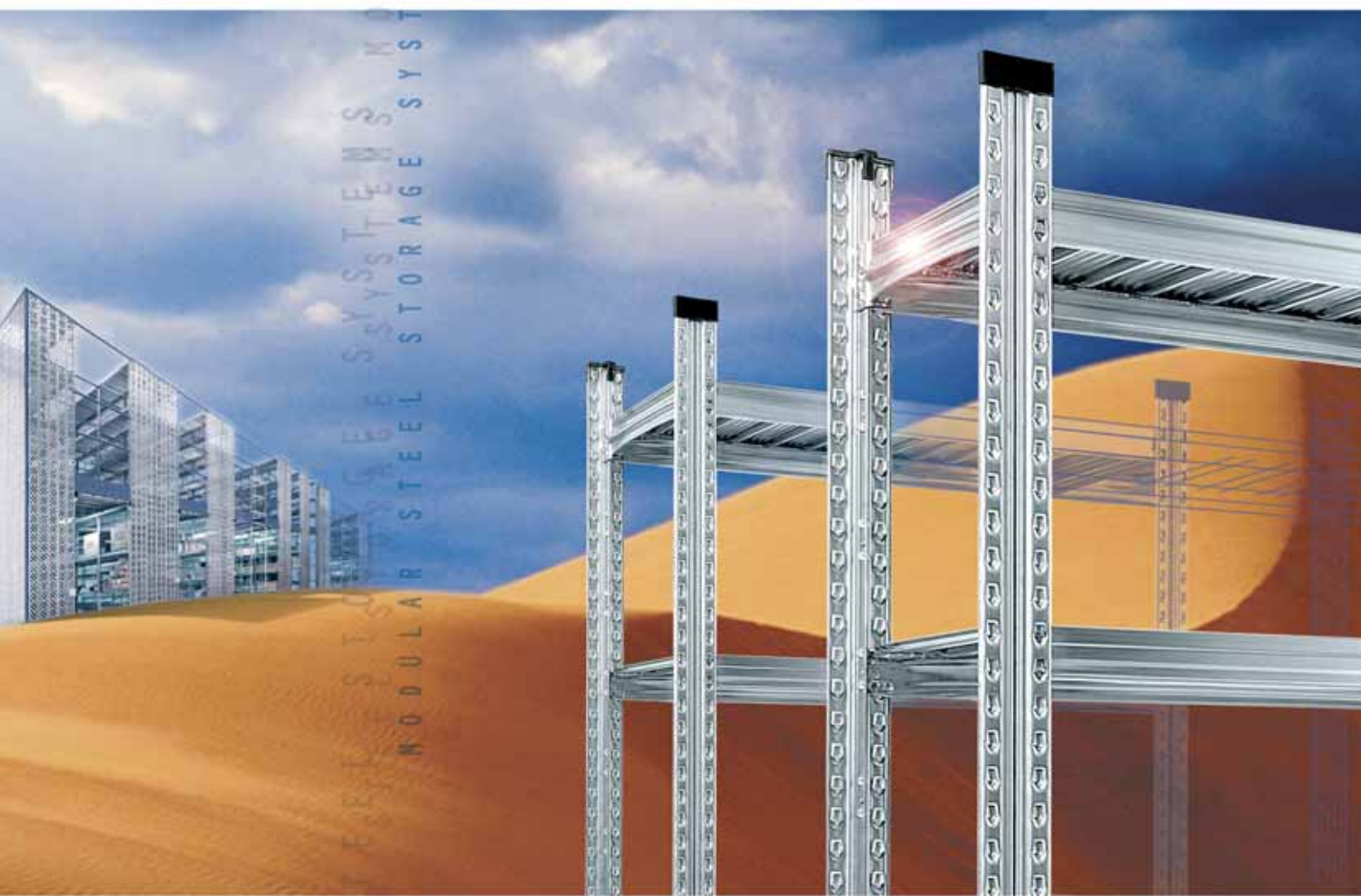

TERMODOMODULAR



METALSISTEM
SISTEMI E STRUTTURE PER IL MAGAZZINO

METALSISTEM

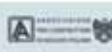

FEM section X

METALSISTEM



38068 Rovereto (TN) - Italy - Viale dell'Industria, 2 - Tel. 0039 0464 303030 - Fax 0039 0464 303031
e-mail: info@metalsistem.com - Internet: www.metalsistem.com



FEM section X

AZIENDE GRUPPO METALSISTEM / METALSISTEM GROUP MEMBERS

SERVIZIO / SERVICE



55 West Beaver Creek Road, Unit #7
Richmond Hill - Ontario - L4B 1K5 - CANADA
Tel. 001 905 8869499
Fax 001 905 8866990
info@metalsistemcanada.com
www.metalsistemcanada.com



P. O. Box 91
Niddrie VIC 3042 - AUSTRALIA
Tel. +61 3 944 97588
Fax +61 3 944 97622
info@metalsistemaustralia.com
www.metalsistemaustralia.com



Philadelphia, Pennsylvania (PA)
Office and Showroom:
428 North 2nd St. Philadelphia, PA 19123 USA
Tel. 001-215-430-0730 Fax: 001-215-430-0731
Warehouse:
3201 Fox St. Philadelphia, PA 19129 USA
Miami, Florida (FL)
2101 W. Atlantic Blvd. Unit 110,
Pompano Beach, FL 33069
info@metalsistemnorthamerica.com
www.metalsistemnorthamerica.com
Toll Free phone number 1-866-412-5558



Rue de l'Industrie, 21
L 8399 Winchhof - LUXEMBOURG
Tel. +352 397205
Fax +352 399230
info@luxmetalsistem.lu
www.luxmetalsistem.lu



Galleistraat, 20
1704 Se Heerhugowaard - Nederland
Tel. 0031 72 5760165
Fax 0031 72 5760169



Via Industria
06514 Lamone - Canton Ticino
SWITZERLAND
info@metalsistemtecnologic.com
www.metalsistemtecnologic.com



63033 Montopridone
Centrocchi (AP) Italy
Via del Lavoro, 16
Tel. 0735 704880
Fax 0735 710413
info@blocksystem.it



80144 S. Pietro a Paterno (NA) Italy
Via Caserta al Bravo, 192
Tel. 081 7385602
Fax 081 7385664
info@logsistem.it



38068 Rovereto (TN) Italy
Viale del Lavoro, 3
Tel. 0464 43 88 66
Fax 0464 43 73 86
info@metalsistemnord.it



60028 Osimo Stazione (AN) Italy
Via Maestri del Lavoro, 17
Tel. 071 710 86 60
Fax 071 710 84 85
metalsi@tin.it
www.metalsistemmarche.it



41012 Carpi (MO) Italy
Via C. Manzoni, 113
Tel. 059 656 450
Fax 059 642 479
info@metalsistememilia.it
www.metalsistememilia.it



20090 Buccinasco (MI) Italy
Via E. Ferri, 6
Tel. 02 45708646
Fax 02 45708647
info@metalsistemlombardia.it



33080 Cusano di Zoppola (PN) Italy
Via Elbero, 11/A
Tel. 0434 97 0 77
Fax 0434 97 1 77
info@metalsistemtirreia.it



07100 Sassari (SS) Italy
Z.I. Predda Niedda Nord, str. n. 3
Tel. 079 260 559
Fax 079 263 3604
info@metalsistem Sardegna@metalsistem.com
www.metalsistem Sardegna.com



00040 Pomezia (RM) Italy
Via dei Castelli Romani, 56/58
Tel. 06 91801333
Fax 06 91621141
info@metalsistemroma.it



37060 Caselle
di Sommacampagna (VR) Italy
Via dell'Artigianato, 24
Tel. 045 858 12 12
Fax 045 858 11 86
info@vierreistem.it



91220 Le Plessis Paté France
11, Rue Léonard de Vinci - Z.I. du Parc
Tel. +33 1 69 88 82 82
Fax +33 1 69 88 83 83
france.rayonnages@wsladco.fr



90142 Palermo (PA) Italy
Via Brigata Aosta, 58/60/62
Tel. 091 362 316 / 547 674
Fax 091 637 45 43
gisistem@inwind.it



10028 Trofarello (TO) Italy
Via Torricelli, 39
Tel. 011 649 75 69
Fax 011 649 84 69
info@metalsistempiemonte.com



06037 Foligno (PG) Italy
Via dell'Industria
Loc. Portose di S. Eracleo
Tel. 0742 39 15 34
Fax 0742 39 36 55
info@metalsistemumbria.it
www.metalsistemumbria.it



50041 Calciano (FI) Italy
Via del Pratignano, 90
Tel. 055 887 36 33
Fax 055 887 46 52
info@sotestasistem.com
www.sotestasistem.com



40026 Imola (BO) Italy
Via Faenza, 4A
Tel. 0542 64 39 81
Fax 0542 64 38 52
info@metalsistemromagna.it



25010 Loc. Fozzano (BS) Italy
Via Tito Saresani, 13/15
Tel. 030 266508
Fax 030 2160301
info@tokosistem.it



35011 Campodarsego (PD) Italy
Via Antoniana, 286
Tel. 049 9201417
Fax 049 5564755
info@centrometalsistem.it



91220 Le Plessis Paté PARIS France
11, Rue Léonard de Vinci - Z.I. Du Parc
Tel. +33 1 69 85 18 45
Fax +33 1 69 84 95 54
info@sidac-evolution.net



Nottingham NG2 1LW ENGLAND
Crossgate Drive, Queens Drive Industrial Estate.
Tel. +44 115 8590182
Fax +44 115 8590183
equipment@metalsidac.com



08110 Moncada i Reixac BARCELONA Spain
C/ Narcís Monturiol n°4 nave 14
Tel. +34 935 651 800
Fax +34 935 651 801
sidac-beria@sidac-beria.com

PRODUZIONE / PRODUCTION



38068 Rovereto (TN) Italy
Viale dell'Industria, 2
Tel. 0464 30 30 30
Fax 0464 30 30 31
info@metalsistem.com
www.metalsistem.com



25064 Gussago (BS) Italy
Via Mandolissa, 100
Tel. 030 25 26 511
Fax 030 25 26 500
info@sidac.net



38068 Rovereto (TN) Italy
Via Caproni, 3/B
Tel. 0464 421 505
Fax 0464 487 266
info@galtre.it



O.S. Křeřt
Slavkov 284
CZ - 687 64 okr. Uherské Hradiště
CZECH REPUBLIC
Tel. +420 572 648615
Fax +420 572 648071
ochohod@kredit.cz
www.kredit.cz



70017 Pulignano (BA) Italy
Via Maestri del Lavoro n.c. - Z.I.
Tel. 080 405 41 54
Fax 080 405 41 43
info@smetar.it
www.smetar.it



21013 Gallarate (VA) Italy
Via Monte Leone, 25
Tel. 0331 79 36 19
Fax 0331 77 04 07
luoni@metalsistem.com



20017 Mazze di Rho (MI) Italy
Via G. di Vittorio, 7/29
Tel. 02 939 00 759
Fax 02 939 00 838
csamagazzini@vibero.it



38068 Rovereto (TN) Italy
Viale dell'Industria, 2
Tel. 0464 438 538
Fax 0464 438 998
i@ideainformatica.com



35011 Campodarsego (PD) Italy
Via Antoniana, 286
Tel. 049 55 66 136
Fax 049 55 66 137
info@metalsistempoint.it

THE GROUP



Founded in 1968, METALSISTEM commenced its activities specialising in the design and production of machinery for the cold profiling of metals.

The experience gathered, numerous highly innovative patents resulting from intense research and development and the considerable market success of the first range of cold form zinc coated profiles quickly channelled METALSISTEM into the production of the latter of its activities.

Today the METALSISTEM Group is an articulated network of companies with its head office and main production facility in Rovereto, Italy.

The Group has consolidated its position as one of the major industries within the Material Handling Sector.

Through products and services aimed at providing complete assistance for all warehousing, product showcasing and sales outlet requirements, the companies of the METALSISTEM Group are able to offer their customers a wide range of products of the highest quality, highly competitively priced, with very rapid delivery times and a first class back up service, as well as tailor made solutions providing efficient and rational use of internal storage areas and material handling environments.

Lightness, strength and modular form, coupled with the ease of integrating and expanding already existing structures are but a few of the successful features of the METALSISTEM storage and shelving systems.

The success of the METALSISTEM Group is the result of a precise managerial choice based on research of new production technologies and continuous development and innovation of its product range.

A direction which has produced numerous international patents (testament to the uniqueness of the METALSISTEM product), continuing improvements in safety, quality and versatility.

METALSISTEM's company strategy is to offer products of the highest quality, very competitively priced, with rapid delivery times backed up by a first class service.

The numerous product lines are conceived and designed by METALSISTEM's internal Research and Development Centre, as are the profiling lines and equipment required for their manufacture.

The automated production facilities for the cold profiling of metals have enabled METALSISTEM to achieve one of the highest levels of productivity in the world, today.

Rigorous laboratory tests are conducted on the prime material entering production, and on the final product, thus ensuring the continuing evolution of efficiency and quality standards.

All products have elevated structural characteristics and ensure high quality standards recognised by the most important European certification bodies, such as Germany's TÜV Product Service GmbH, Austria's Ö-NORM, Rome's I.S.P.E.S.L., ACAI/CISI (Associazione Costruttori Acciaio Italiani - Sezione Costruttori Italiani di Scaffalatura Industriale), the latter of which METALSISTEM has membership, and others.

The company's ISO 9001 quality assurance system is certified by IGQ.

With an annual turnover of exceeding 260 Million Euro, the METALSISTEM Group premises occupy a total area of 230.000 m², 125.000 of which are dedicated to production.

The METALSISTEM Group affiliated companies and distributors provide a world wide commercial network covering the domestic market and the industrialised nations of the world, able to satisfy the most demanding needs.

We value greatly the high level of trust that is placed in us by our customers and feel that it is proof of the quality and reliability of our products.



STANDARD SPECIFICATIONS CALCULATION AND SAFETY STANDARDS

The correct use of the product, both from the technical and design point of view indemnifies both the manufacturer and the customer in the event of improper use. Therefore, METALSISTEM recommends that customers follow its code of practice for design and utilisation of its products.

Ref. N°:	SUPER 2
System:	2005
Year of Construction:	2000 daN
Frame Load Capacity (u.d.l.):	200 daN
Shelf Load Capacity (u.d.l.):	10 daN
Weight of Load Unit:	700 mm
Distance between ground and first beam level:	

METALSISTEM declines all responsibility for improper or non authorized use of the racking and its accessories.

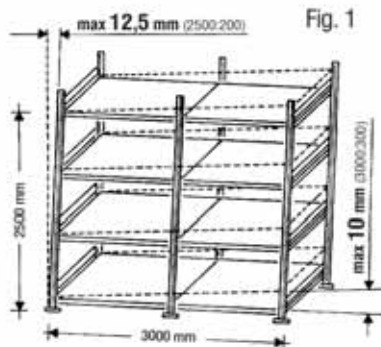

a) Floor slab loading.

Loading capability should be checked before installation.

b) Site installation. It is of utmost importance that installations are assembled by skilled labour only.

Fig. 2



Frames should be built in strict accordance with the assembly diagram shown at right. Particular attention should be paid to a proper assembly and location of security pins.

c) Rack alignment.

Once the shelving is assembled, it is necessary to align it vertically and horizontally. The perpendicular deviation should not exceed 1/200 of the height (with a maximum

of 15 mm) and correspondingly the horizontal deviation 1/300 of the bay length. See fig. 1.

d) Load bearing capacity plate.

Load capacity plates should be fixed in a prominent position and show the product series, the year of construction, the maximum load per bay, per shelf and per sq.mt. (in the case of platforms and/or two-tier-structures), as well as the weight of the load units and the distance from the ground to the first load level.

e) Rack safety standard.

In the case of hand loaded static shelving, if the height of the frame is over 3 metres or exceeds over 5 times its depth, the frames must be securely bolted to the floor slab (using the heavy duty base plate art. 67006) and fitted with wall ties or overhead ties (see fig. 2). It is not allowed to use single sided shelving that exceeds over 8 times its depth, unless the frames are connected through walkways or fitted with wall ties or equivalent. The use of cross bracings (vertical and horizontal cross bracing) is necessary in the case of rack runs with frame heights over 3 metres, with less than 4 bays or with distances of more than 700 mm in height between the load levels. The frames must be securely bolted to the floor slab using the heavy duty base plates (art. 67006) and the locking frame spacer bars. As an alternative solution to the use of cross bracings customers may fit the shelving with wall ties or similar. This is valid only in case that the wall or the structure is adequate for that scope and provide an equal or better grade of constraint compared to cross bracing. Within seismic regions it is not allowed at all to use any type of wall ties or similar. For specific calculations and design customers should contact the Metalsistem Technical Department.

f) Installation design.

SUPER 123 structures are to be used as hand loaded shelving only and not as pallet racking, with forklifts, or with wheeled equipment on two-tier-structures. METALSISTEM declines all responsibility for improper or non authorized use of the shelving and its accessories.

g) Two tier structures/platforms.

Two tier structures with suspended walkways are to be designed exclusively with the SUPER 3 system and must comply with all safety recommendations. In case of platforms with continuous floor/decking (see page 5 - case "B"), the frames are to be assembled as shown in the assembly diagram, i.e. using exclusively diagonal spacer bars, at centre distances of 264 mm, up to the level of the platform. Uprights must be assembled with locking frame spacer bars and heavy duty base plates (art. n° 67006), securely bolted to the floor slab. Staircases must be adequately reinforced and built with the reinforced SUPER 3 uprights only (art. n° 99230), either side of the staircase. The correct use of all safety components mentioned in this brochure is obligatory. The maximum load bearing capacity of walkways/decking within two-tier-structures and platforms is 300 kg/m², the maximum width of walkways is 1200mm, and the maximum shelf bay length is 1500 mm. The frames must be fitted with overhead ties (art. n° 67401).

h) Software reference.

The theoretical calculation is based on the EURO-CODE 3, using the safety factors recommended within the F.E.M. standards. The reference standards for the materials are the following:
-EN10204 - EN10142 - EN10147

i) Calculation. The calculation is executed with the ANSYS software and based on finite elements.

l) Frame load capacity. The frame load bearing capacities stated in this brochure are calculated in compliance with the following criteria: the first shelf level must be fitted at no more than 700 mm from the ground and the following levels at intervals not exceeding 500 mm, with a minimum of 4 interconnecting bays. Frames are to be bolted to the floor slab.

m) Shelf load bearing capacity.

Data for shelf load bearing capacities shown in the brochure are to be understood as referring to uniformly distributed loadings with a deflection equal to 1/200° of the shelf length. The beam locking pins must always be fitted.

n) Custom-built applications.

The METALSISTEM Technical Department is at its customers' disposal for any specific calculation or custom-built application.



METALSISTEM reserves the right to apply technical changes to the product. Data, characteristics and dimensions given in this document are merely indicative.

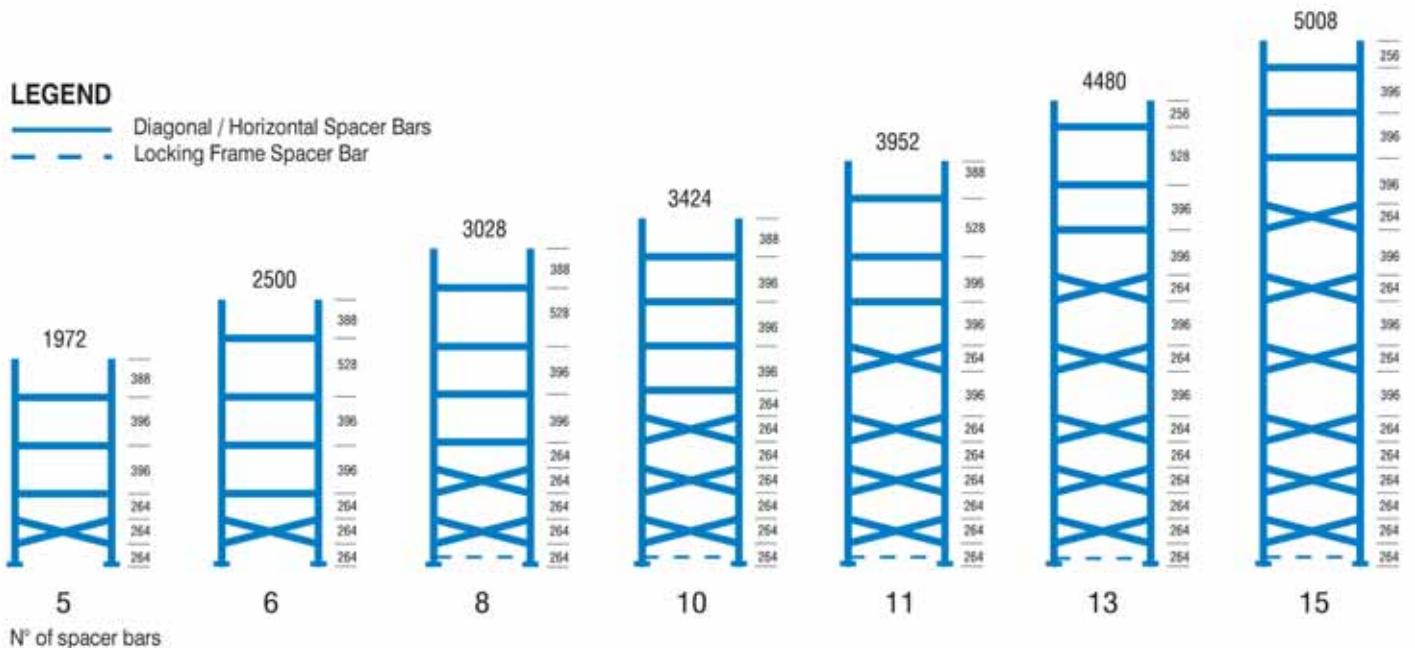

DIAGRAM FOR ASSEMBLING BRACING FOR FRAMES

320 - 400 - 500 - 600 - 700 - 800 mm in depth

LEGEND

-  Diagonal / Horizontal Spacer Bars
-  Locking Frame Spacer Bar



SUPER 1/2/3 is made from certified steel and carries the approval mark of TÜV PRODUCT SERVICE GmbH



TWO TIER STRUCTURES PLATFORMS

In case of two tier structures with suspended walkways the frames are to be assembled as shown in case "A" at left (i.e. the standard frame assembly diagram). In case of platforms with continuous floor decking, the frames have to be assembled with pairs of diagonal spacer bars only, at centre distances of 264 mm, up to the level of the platform (see case "B" at left).

In both the cases the frames must be securely bolted to the floor slab using the heavy duty base plates (art.n° 67006) and the locking frame spacer bars.

Staircases made from standard components and integrated into the two-tier-structure have to be reinforced in an appropriate way, using the reinforced SUPER 3-upright (art.n° 99230) either side of the staircase. METALSISTEM strongly recommends to comply with all safety standards mentioned in this brochure. The maximum load bearing capacity of walkways/decking within two-tier structures or platforms is 300 kg/m² and the maximum width of the walkways is 1200 mm. The maximum shelf bay length is 1500 mm.

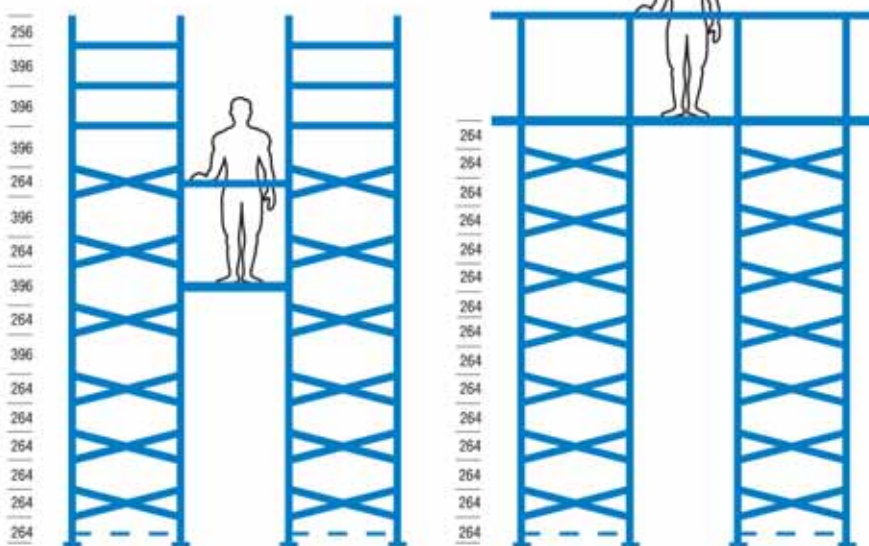

CASE "A"
Two tier structure with suspended walkways

CASE "B"
Platform with continuous floor

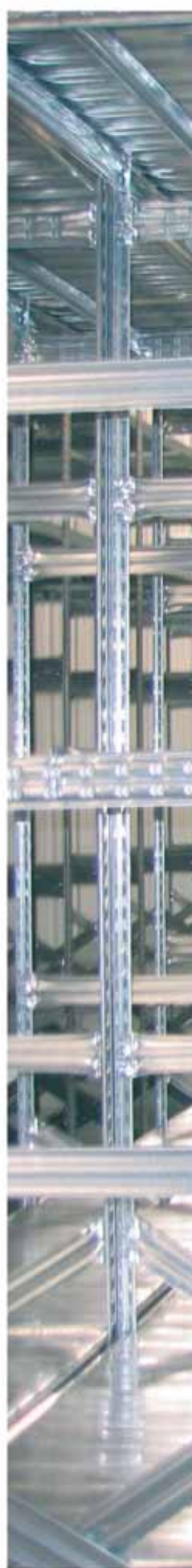



THE COMPANY TODAY

METALSISTEM products are now in use in a great many installations throughout the world, and after more than 30 years production, we value greatly the high level of trust that is placed in us by our customers and feel that it is proof of the quality of our products.

The shelving components are produced on fully automated production lines.

The folding and cold processing techniques developed by METALSISTEM are designed to obtain light and extremely strong components.

Lightness, strength and modular form, coupled with the ease of integrating and expanding already existing structures are but a few of the successful features of the METALSISTEM Industrial Storage Systems. Ideal storage solutions for a whole host of products supplied worldwide are created here thanks to a total commitment to research and development.

All METALSISTEM components are subjected to regular and rigorous technical tests. These cover both uniformly distributed and concentrated loadings.





THE PRODUCT

The fully adjustable SUPER 1/2/3 systems have been designed to meet the needs of light to medium duty storage. They are also highly suitable for the construction of two tier structures (with the SUPER 3 system). The design of the various components is the result of rigorous technical testing and the highly specialised knowledge developed over years of experience in the field of metal processing.

This experience has enabled METAL-SISTEM to offer innovative products of the highest quality, highly competitively priced, and to produce a highly technical solution to the most important



shelving problems, such as rapid assembly, stability, low cost and load bearing capacity.

The design allows for high load bearing from light gauge materials. The use of high quality zinc coated steel ensures a high level of durability.

The structural components of the SUPER 1/2/3 systems are made from high tensile steel, certified according to EN 10204 3.1B.





The safety and the quality of the product has always been a primary aim of METALSISTEM and is recognised by TÜV PRODUCT SERVICE in Munich, one of the most rigorous E.C. commissions in the field of quality and safety certification. The product meets the requirements of the Equipment Safety Law.

Thanks to its attractive high-tech design, SUPER 1-2-3 shelving is pleasing to the eye and can provide unique solutions for applications in domestic environments. See examples at left.

ASSEMBLY INSTRUCTIONS

Base plates

Fit the metal base plate onto the upright, using pliers to guide the two tongues on the plate into the ribs on the upright. Then tap the base plate into the ribs with a hammer. Plastic base plates should be used for the SUPER 1 system only (Ref.1). Double plastic base plates are available for back-to-back bays.

These can also be used as top caps for double uprights (Ref.29).

Heavy duty base plates (Ref.1b) must be used in the following cases:

- when building platforms and/or two-tier structures with suspended walkways;

- when building staircases, under the uprights of the staircase;
- if the height of the shelving is over 3 metres or exceeds over 5 times the depth of the shelving;

In all the other cases customers may use the normal standard base plates.

Heavy duty base plates are always to be assembled in conjunction with locking frame spacer bars.

Spacer bars

To fit spacer bars, refer to the diagram on pages 4/5 to determine the exact position and quantity.

Insert the horizontal and diagonal spacer bars into the grooves in the corner of the upright, locating the wide part of the slot over the ribs on the upright and keeping the spacer bars tight to the upright, in order to keep it square; then tap down into the narrow part of the slot alternating from side to side.

To achieve correct assembly, the spacer bar anti-release tongues should be closed (Ref.2).

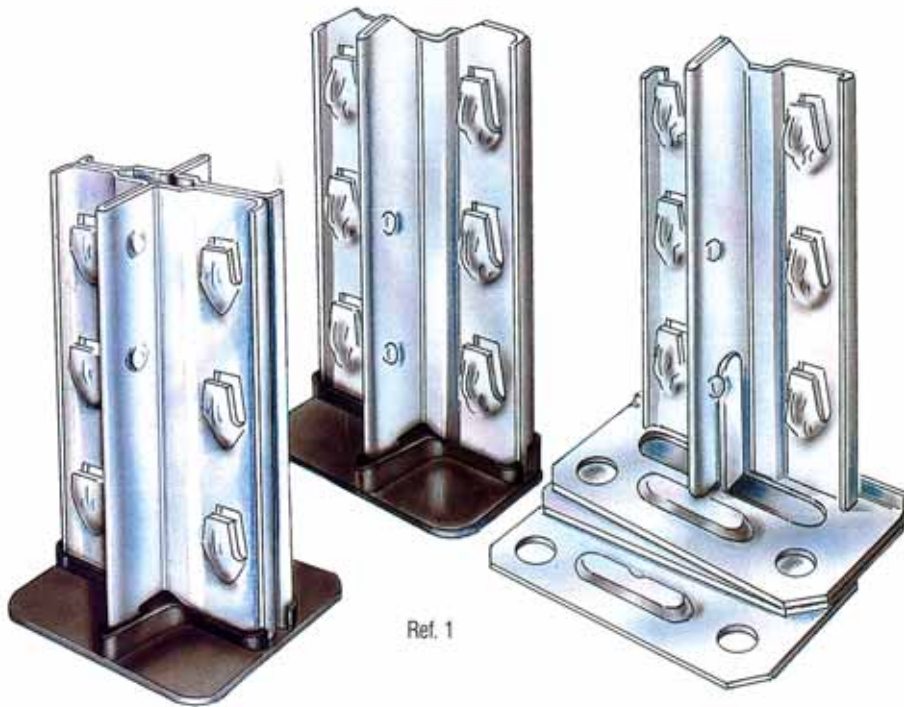

Ref. 1

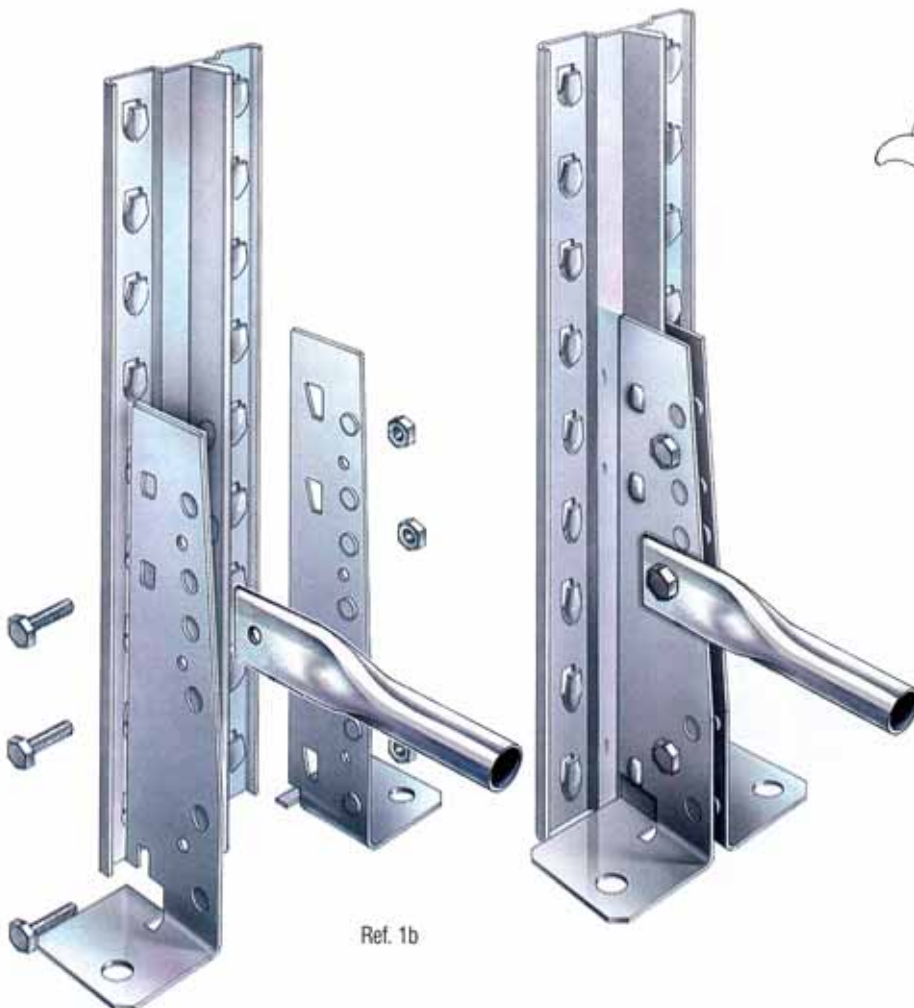

Ref. 1b

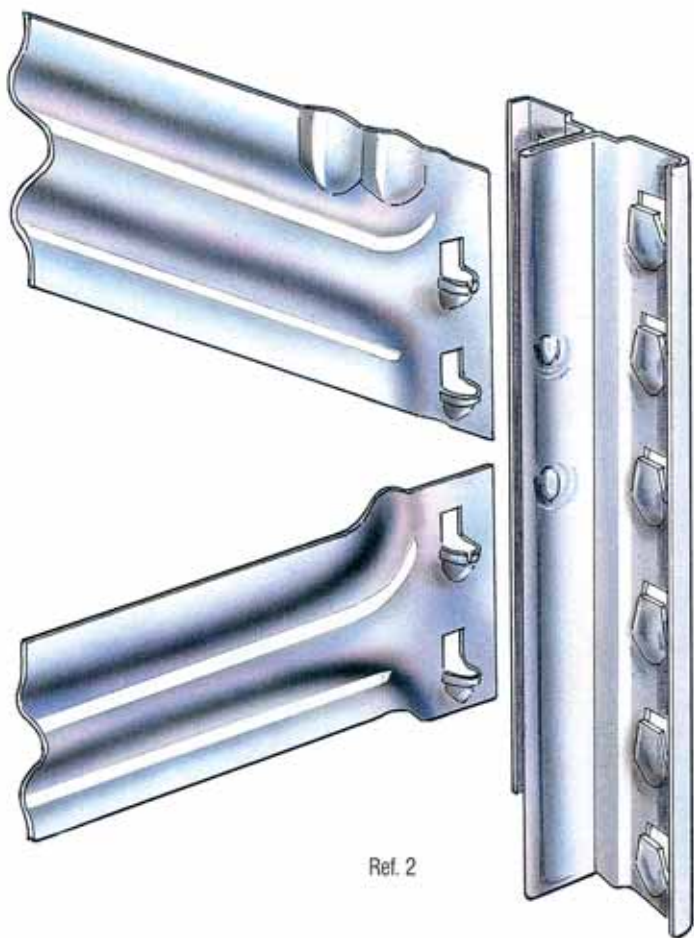

Ref. 2

Beams

Take the frames, assembled with bracing and base plates: keep them as perpendicularly as possible and fit the beam by tapping it down onto the tongues, close to the upright,

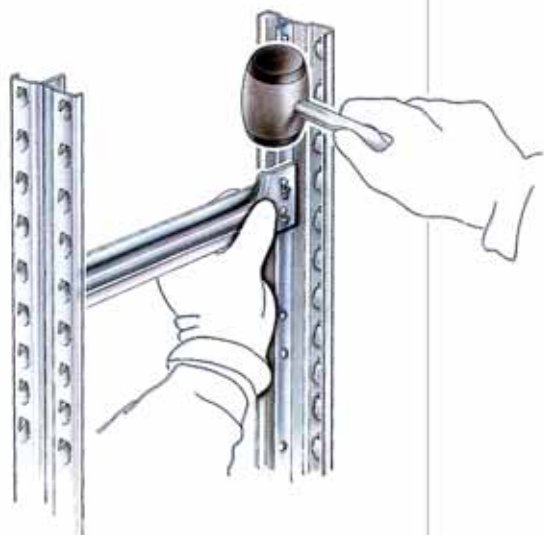

with a plastic-faced hammer to avoid damage to the beam (Ref. 3). The beams, once assembled, should be secured with the respective beam locking pins (see page 21, Ref. 22).

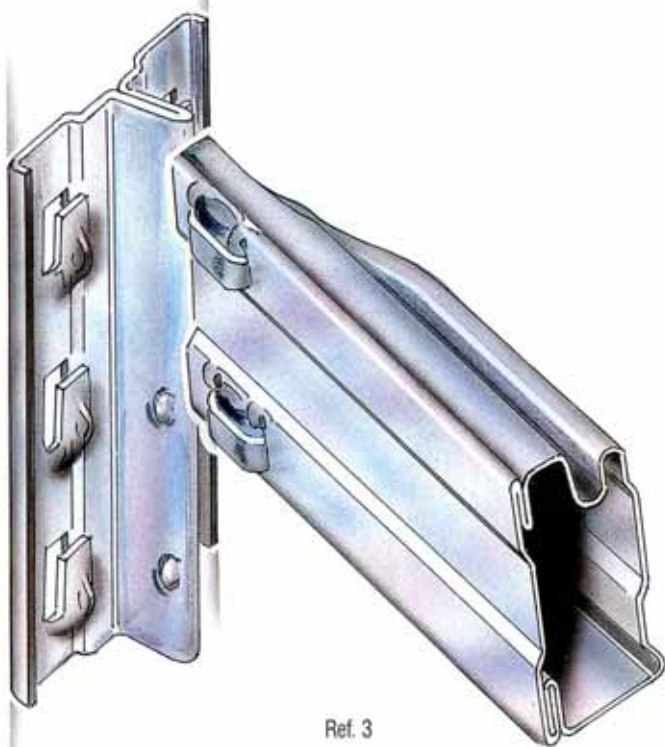

Ref. 3

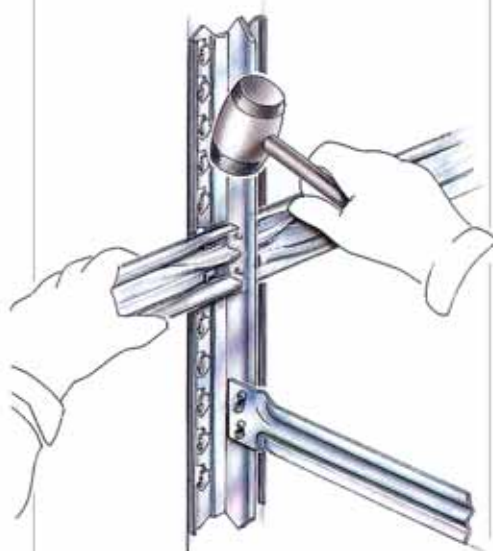

For the storage of tyres or round materials which are placed directly onto the beams, plastic strips are available to avoid damage to the products stored; these strips are fitted into the recess of the beams (see page 21, Ref. 21).



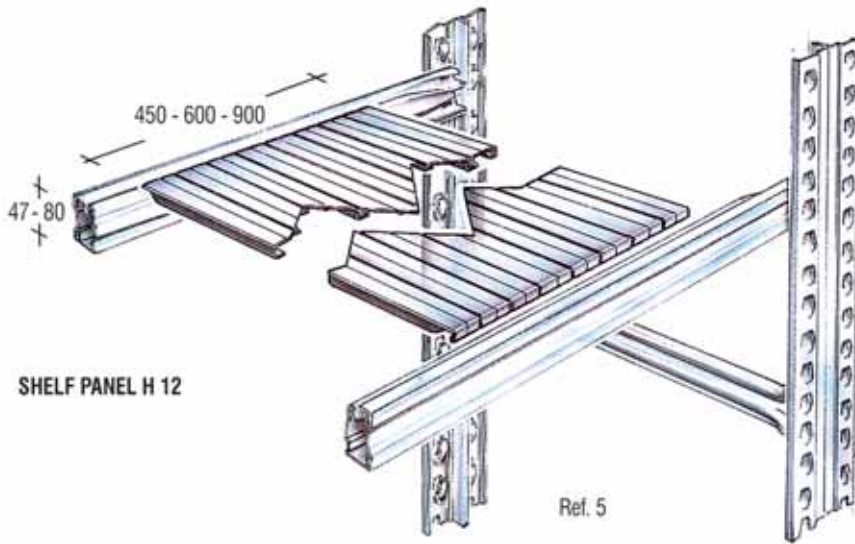

SHELF PANEL H 12

Ref. 5

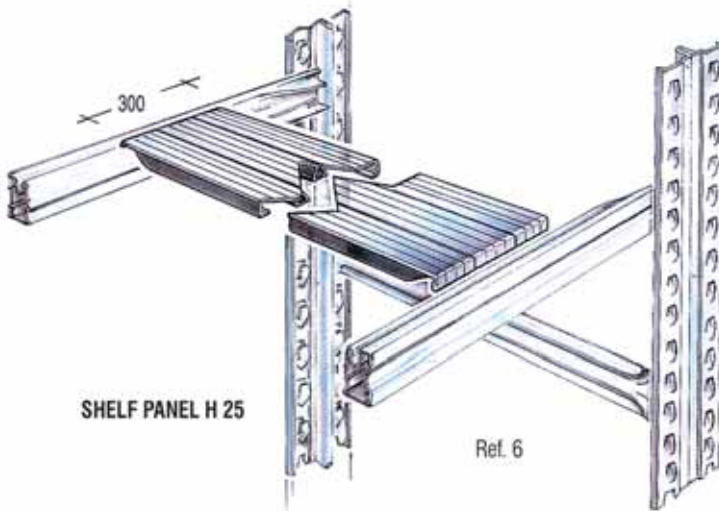

SHELF PANEL H 25

Ref. 6

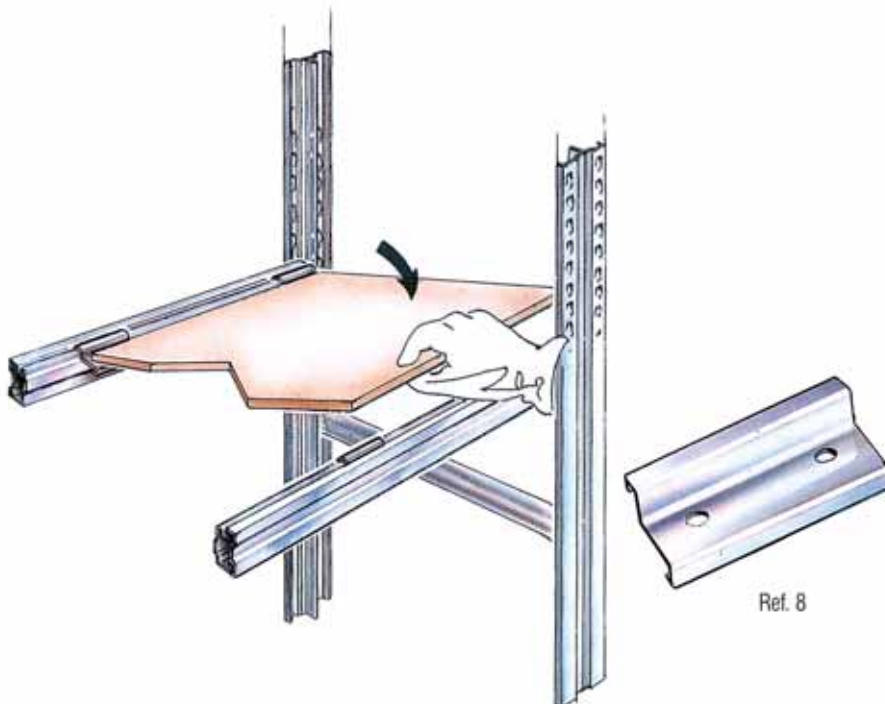

Ref. 8

Shelves

Shelves of profile 12 mm, 450-600-900 mm wide, are produced in depths varying from 320 to 700 mm. Shelves of profile 25 mm and 300 mm wide are supplied in depths varying from 400 to 800 mm (Ref. 5-6).

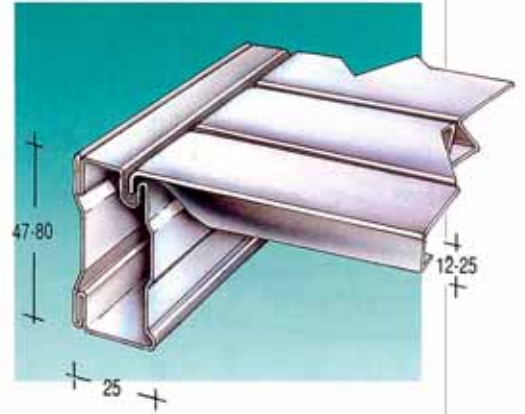

Ref. 6 bis



Chipboard shelves

Chipboard shelves of thickness 12 or 18 mm can be fitted using the clips shown at left (Ref. 8).

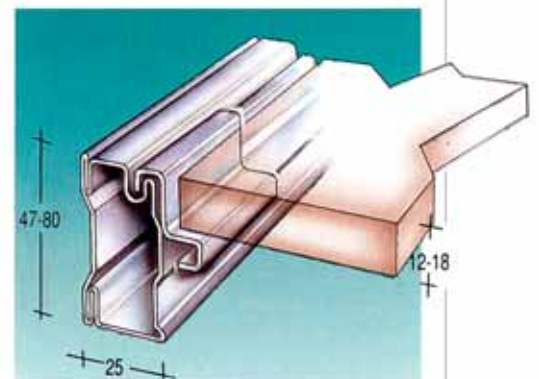

Modular containers

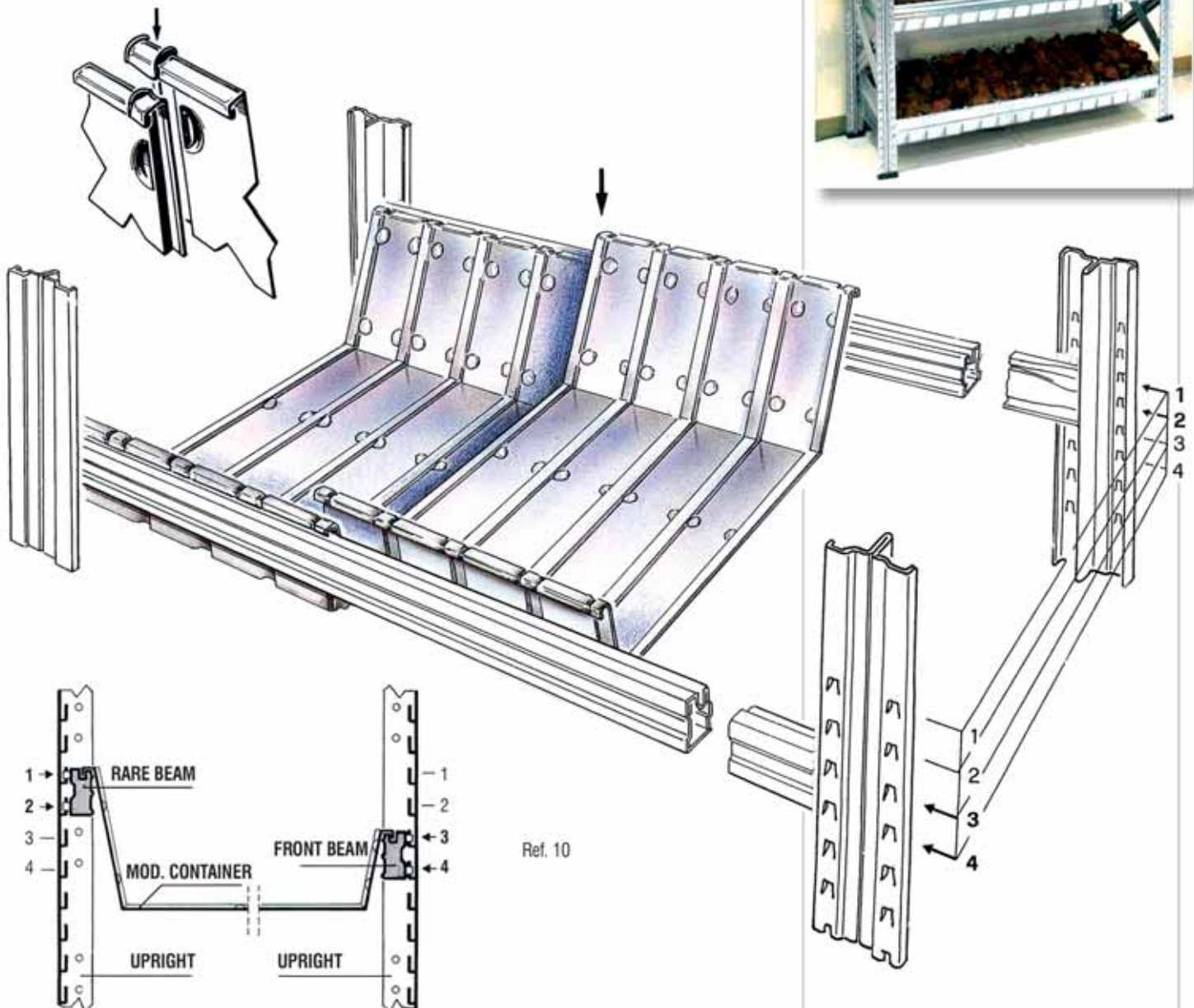
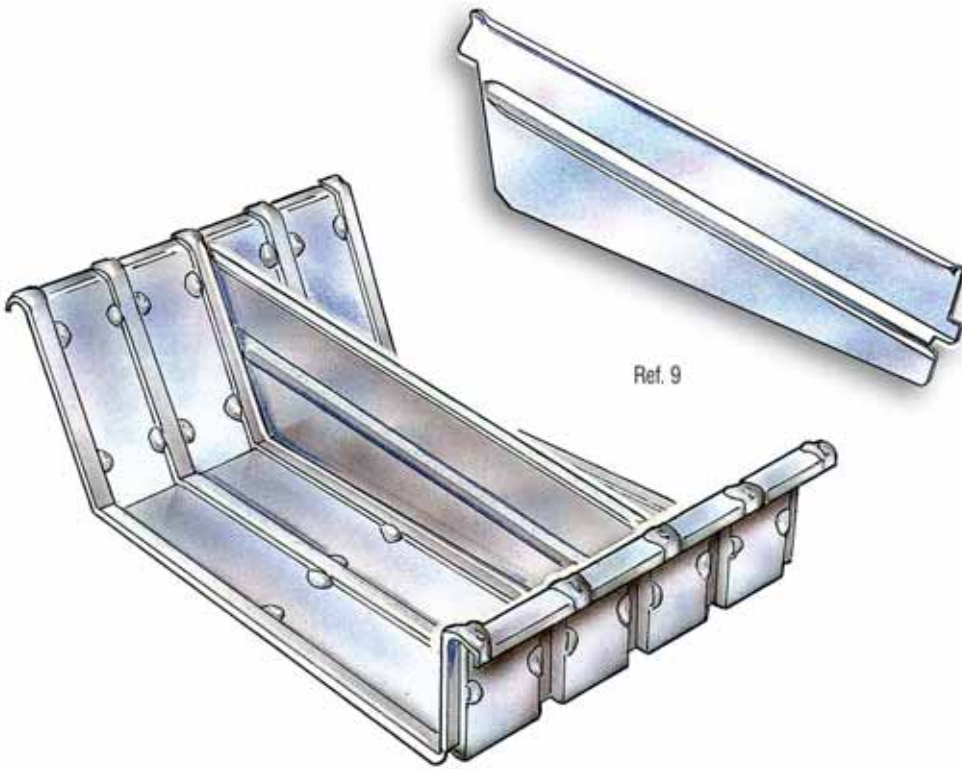

Insert the containers from left to right, and join them together by overlapping the beginning of the following container onto the end of the preceding one, pressing them into the recess of the beams.

To assemble the containers correctly, the rear beam should be fitted two pitches higher than the front one (Ref. 10).

Fit the dividers into the special slotted seats, pushing down to locate (Ref. 9).

When exceeding the depth of 800 mm, it is advisable to use back-to-back bays, to increase stability.



The capacity of the containers can be increased by fitting bin front and rear panels 200 or 300 mm high.

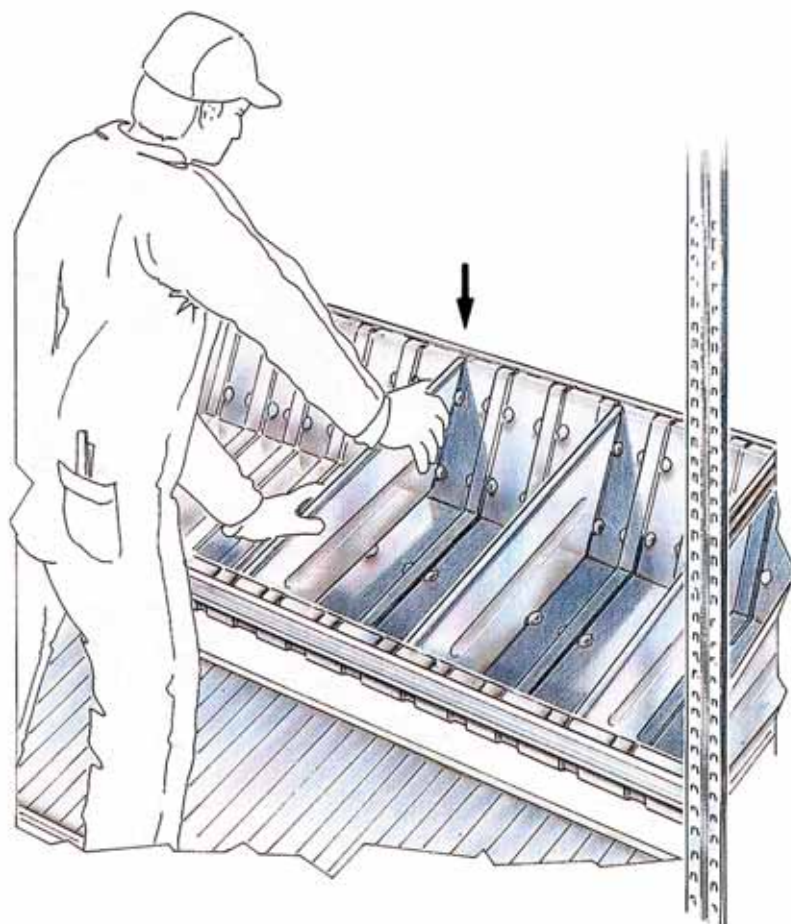

DIVIDERS

A large range of dividers is available.

Vertical sliding dividers

These have been designed to separate loose items (Ref. 11). The concept of these dividers is based on the following components: a couple of clips (version at right/at left), and vertical dividers, available for all frame depths and in two different heights (H=100mm / H=200 mm), as well as in the profiled version (H200/100 mm).

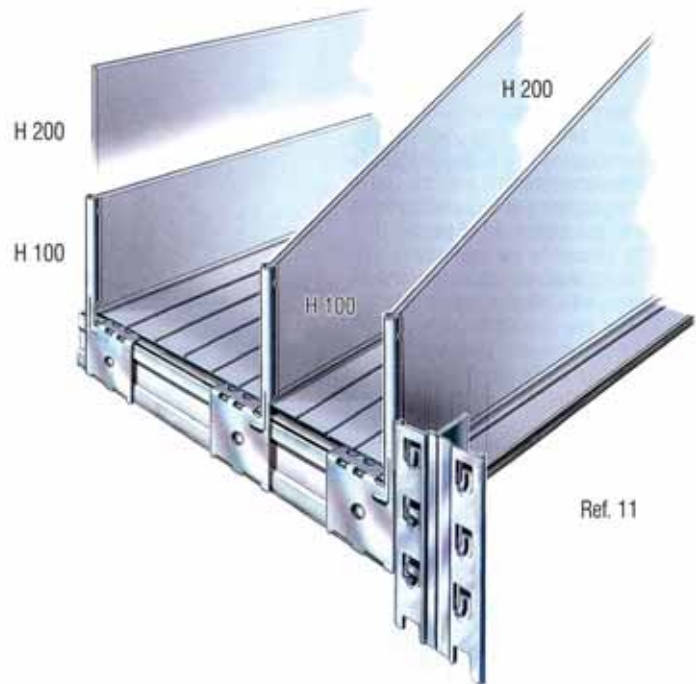

Shelf trays

These comprise a bin front and rear panel 100 mm high placed on a normal shelf with adjustable dividers from 320 to 600 mm in depth (Ref. 13).

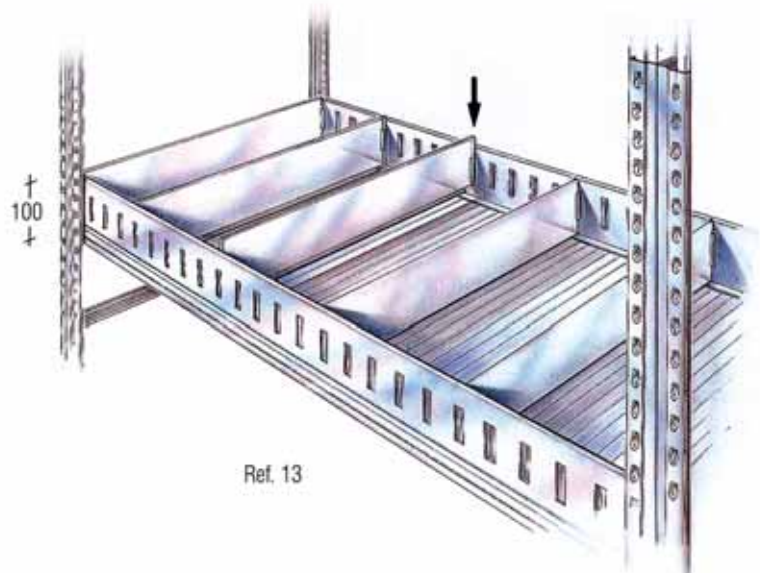

Chest of drawers

The modular drawers are fully integrated with the SUPER 1-2-3 series and are located directly on the frames. A cost effective solution for the storage of small items.



Bin front panels 100 mm high and rear panels 200 mm high are fitted with profiled dividers (Ref. 14/15).

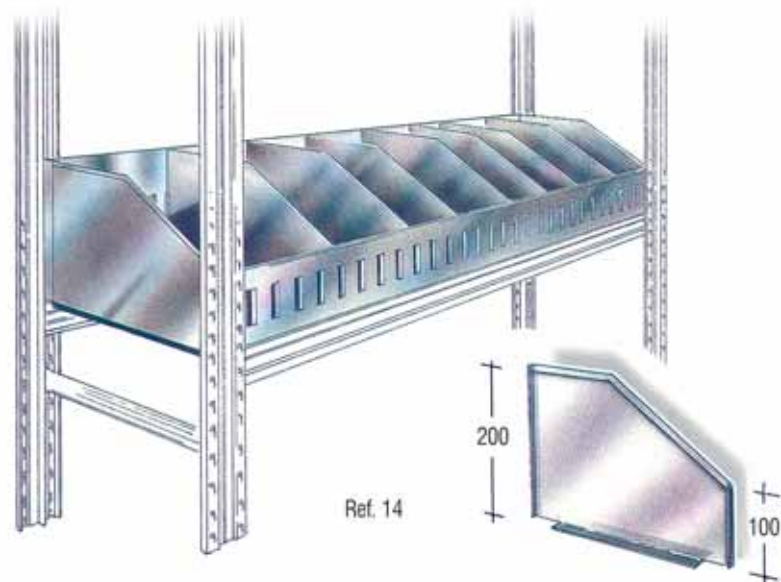
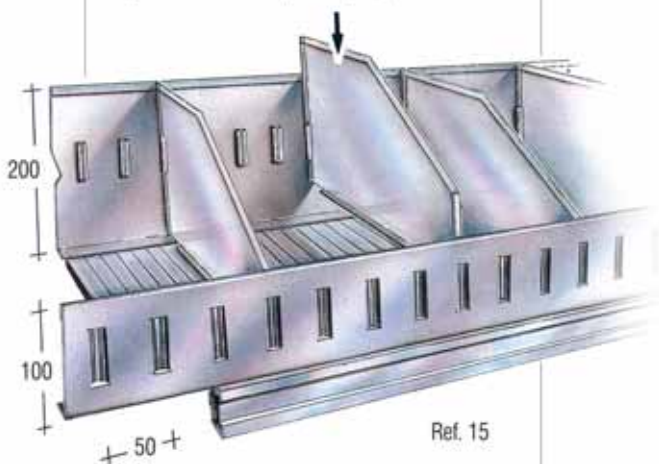



Plastic Bins "Bull Series"

Open fronted plastic bins are also available for the storage of loose items. More information on page 39.



Fixed height dividers

Available in three different heights: 244-344-444 mm. They can be inserted in any position on the shelf by means of spring clips located on the beams H47 (Ref. 16).



Ref. 16

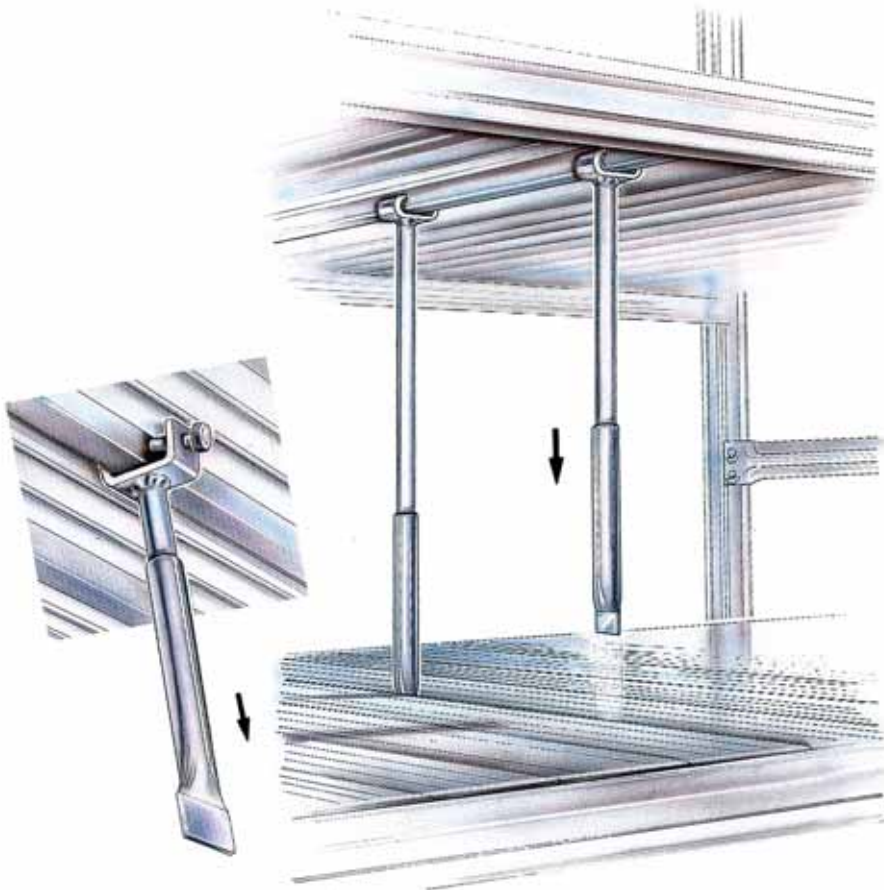

Ref. 17

Telescopic Tube Dividers

Used for the separation of cylindrical components or materials difficult to store (windscreens and panels, etc.). They comprise 2 tubes of 18 mm diameter sliding one inside the other. They are fixed to the upper shelf by means of a clamp/screw connection (8MA). A minimum of two tubes should be used for each division (Ref.17).



Dividers for exhaust pipes

Spigots designed for the separation of tubes, exhausts and conduits, etc. They are used both vertically and horizontally and are fitted on to the beams anywhere in the length (not suited for hanging loads) (Ref.18).

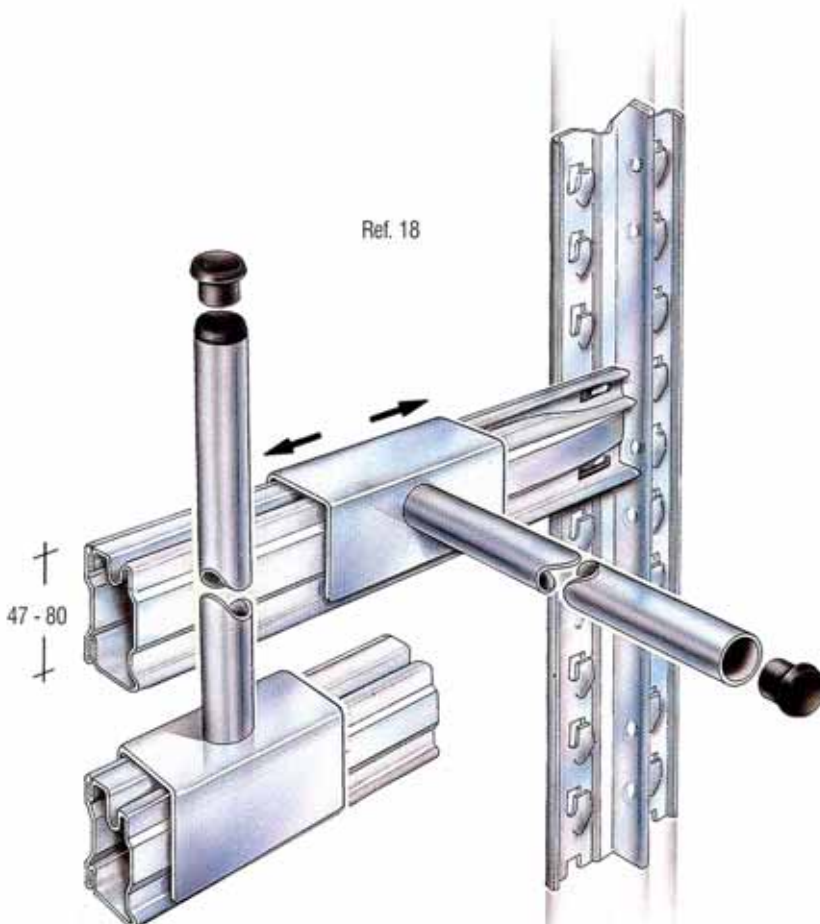

ACCESSORIES

P.V.C. top caps.

PVC top caps are to be fitted onto the top of the upright, in all applications (Ref. 20).

Oval shaped tubes and beams.

The oval shaped beams and tubes are compatible with most types of hanger and provide a cost effective solution to garment storage and for hanging loads (Ref. 19 / 20). The garment hanging shelving can be designed on a single or double entry basis and equipped with shelves. The oval tubes fitted onto the spacer bars alone will not stabilise the structure in the horizontal plane and have to be combined with beams above and below.



Tyre Storage.

The oval shaped beams can also be used for the storage of tyres (see page 10).

In this case, please refer to the technical handbook to identify correct use and appropriate load capacities.

In the case that the tyres will be stored on H-47-mm beams, it is obligatory to use the SUPER-3 version only and exclusively, both for the beams and the frames. Maximum allowed bay length: 1200 mm. Maximum allowed frame depth: 400 mm, to ensure safe storage and to prevent torsional deflection of the beams.

Plastic strip for glass shelves.

It can be fitted on the beams in order to protect glass shelves or delicate materials (Ref.21).

Security pins.

In order to prevent accidental lifting of the beams and shelves, the security pins should be used in all applications (Ref.22). Assembly instructions as per the sketch at right.

Label Holder

It can be located in any position on both H47 and H80 beams.

Dimensions 100x40 (Ref.23).

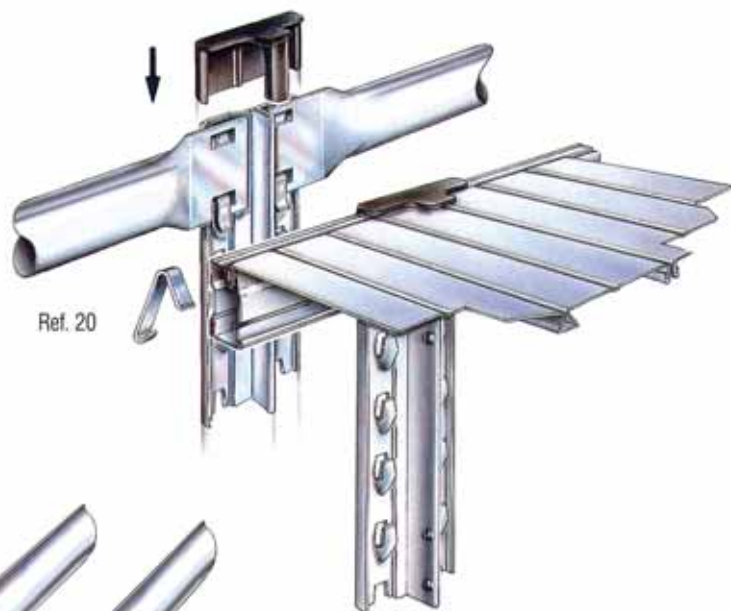

Ref. 20

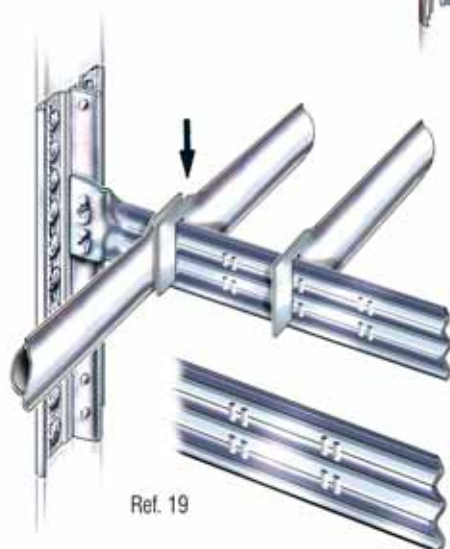

Ref. 19

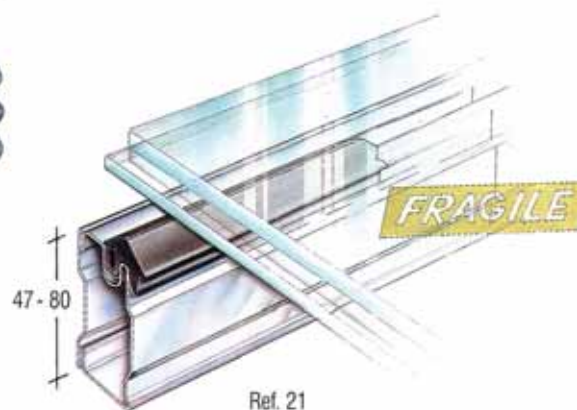

Ref. 21



Ref. 22



Ref. 23

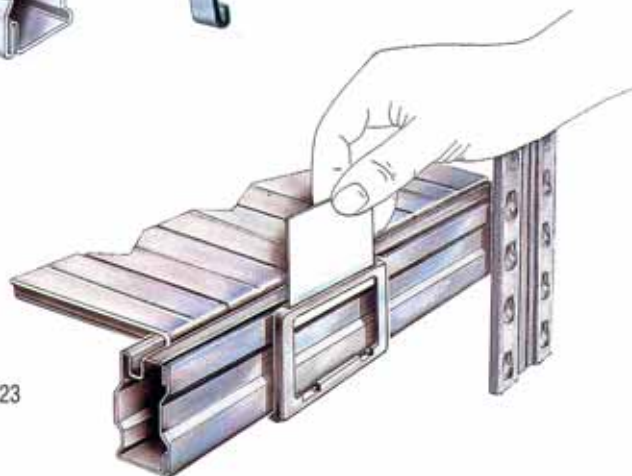

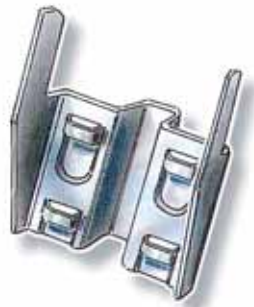

Ref. 24

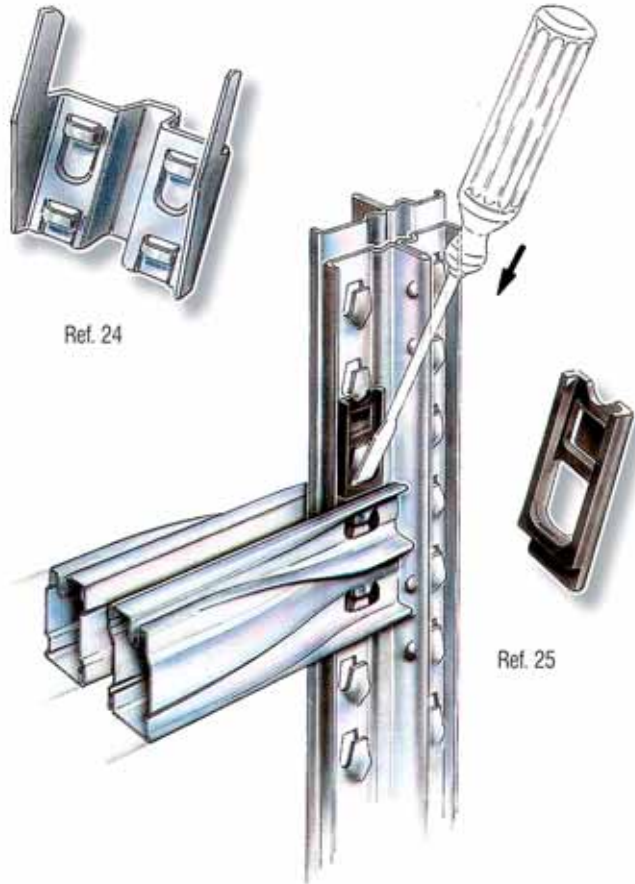

Ref. 25

Frame back-to-back clips

They are used to fix the frames together when building back-to-back bays to improve stability. They are located at mid height (Ref. 24).

Security pins for beams in back-to-back bays

They are used to prevent accidental lifting of the beams when building back-to-back bays (Ref. 25).

CLADDING BACK AND END PANELS H25

Back and end panels are produced in two standard sizes (200 wide x 25 mm profile and 300 wide x 25 mm) and in varying heights of 1485-1940-2480 mm. Back and end claddings in any dimension can be built up in a modular form, using channel profiles "U" and "H" as end and middle joints (Ref. 26).

Ref. 26



In the case of the standard modular back/end panels being lower than the respective frame, "H"-section profiles may be used at the bottom of the panels, to achieve equal height (Ref. 31).

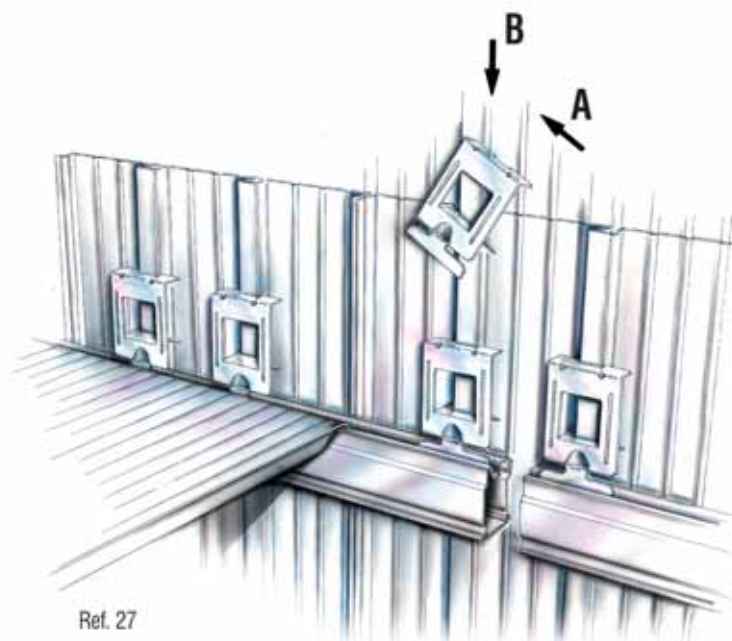

Punched hole back and end panels H25 (according to European Standard) are also available, similar to those described before, with 5 mm holes at 25 mm centres. Special fixing clips are used to fasten the back cladding (Art. 68108 - Ref. 27) and frame end panels (Art. 68107 - Ref. 28).

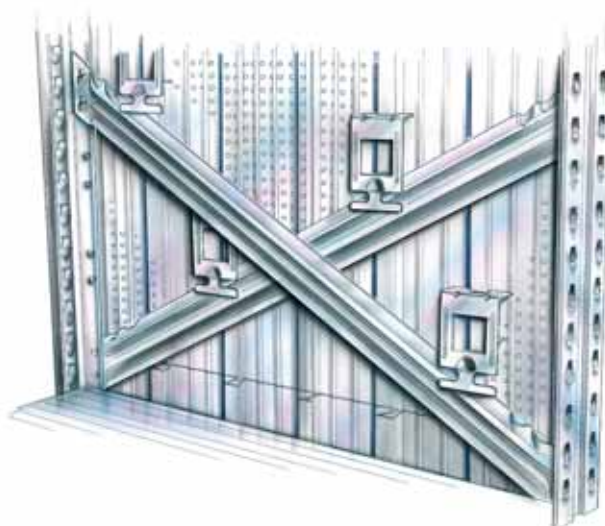
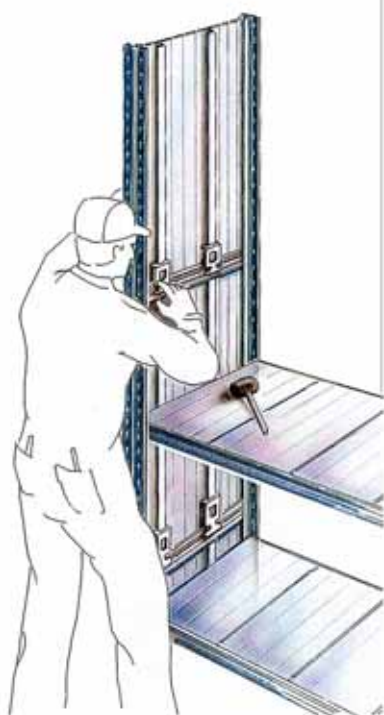

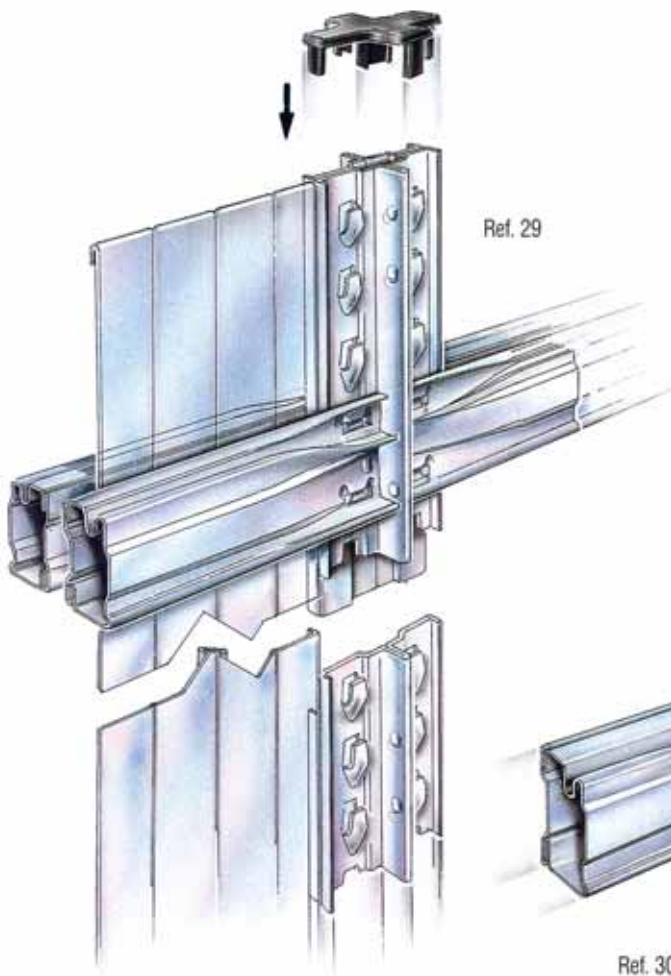

Ref. 29

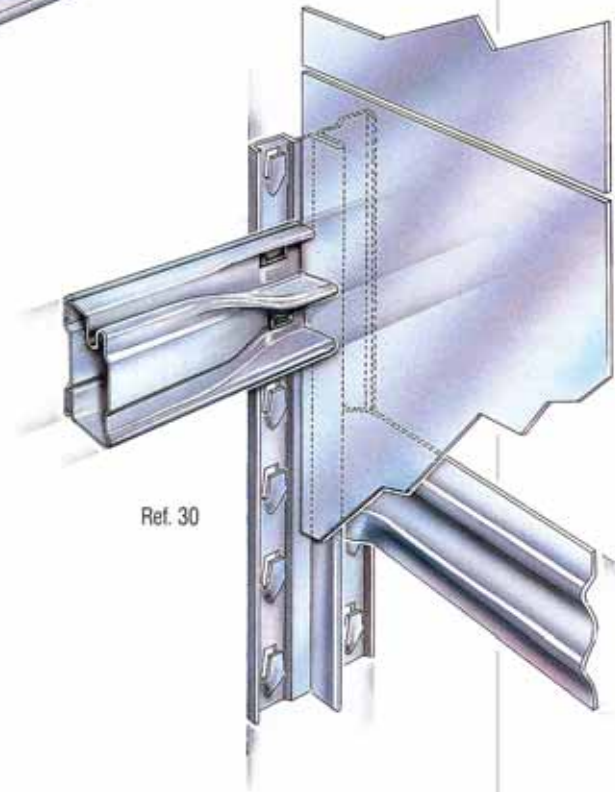

Ref. 30

Back panels H 12 for back-to-back bays

These panels are produced in 600 and 900 mm wide modules and respective compensation panels and in varying heights of 1485-1940-2480 mm (Ref. 29). Any combination in height in the case of back-to-back bays can be made by locating a couple of SUPER 1 beams at junction points, as shown in the sketch at the bottom at left (Ref. 31).



Ref. 31

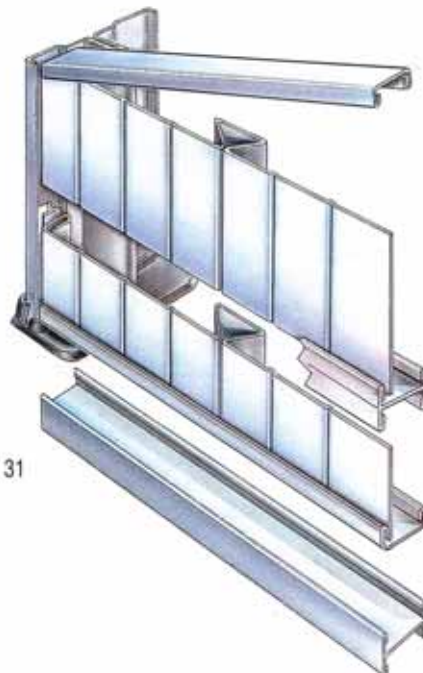

Side cladding

This type of cladding can be used to enclose individual bays within shelving runs and is available for all frame depths. Side cladding panels are fitted between the diagonal spacer bars of the frames. Side frame claddings of any height can be provided combining modular standard cladding panels locating "H" section middle joints (Ref. 30).

When ordering side frame claddings, the respective frames should be built with diagonal spacer bars only; i.e. the horizontal spacer bars have to be replaced with diagonals.

The sketches shown below and beside explain the design and assembly of the various cladding components.

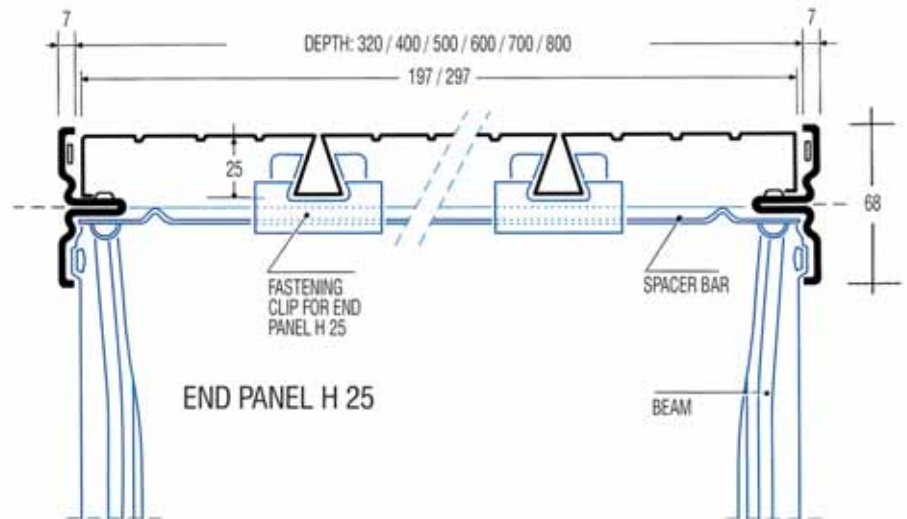

BACK PANEL H 25

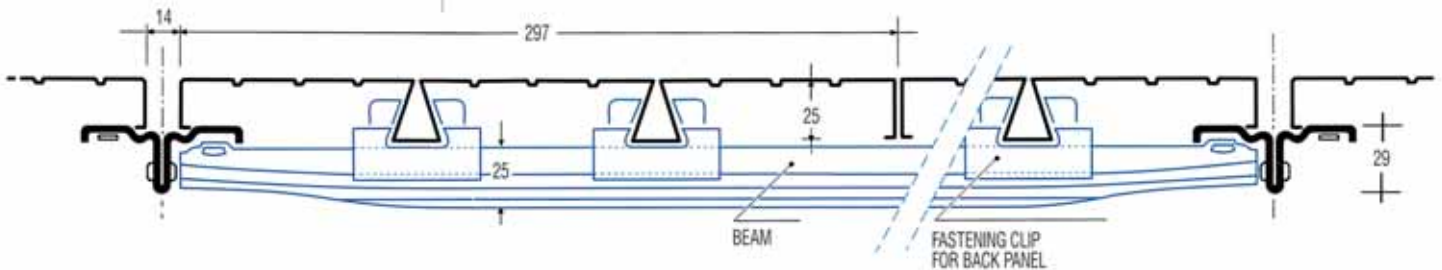

BACK PANEL H 12 FOR BACK-TO-BACK BAYS

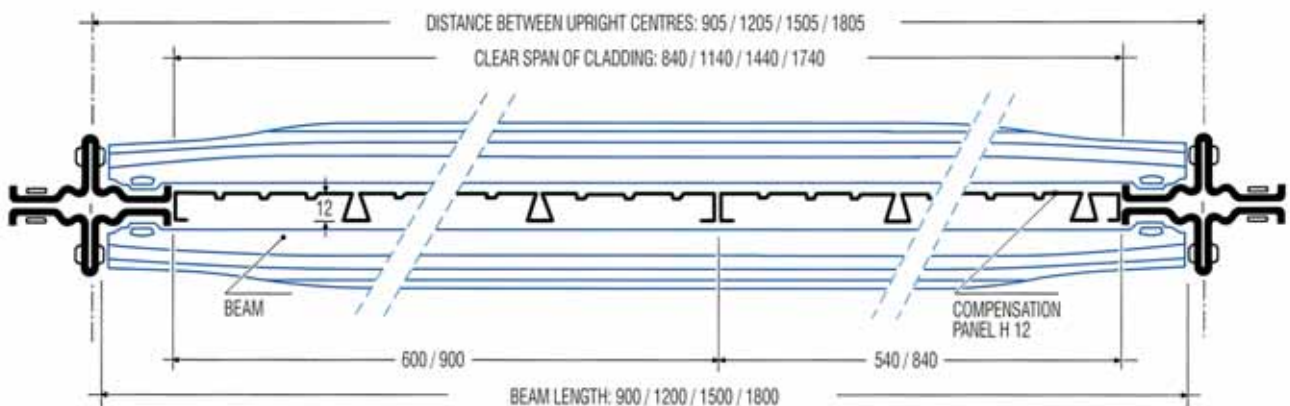

SUPER 3

Two-tier-structures with suspended walkways

(max. load bearing capacity = 300 daN/m²)

Two tier structures, even varied and complex have been designed by METAL-SISTEM combining light weight with high strength in the METALSISTEM tradition, avoiding any type of bolting or welding.

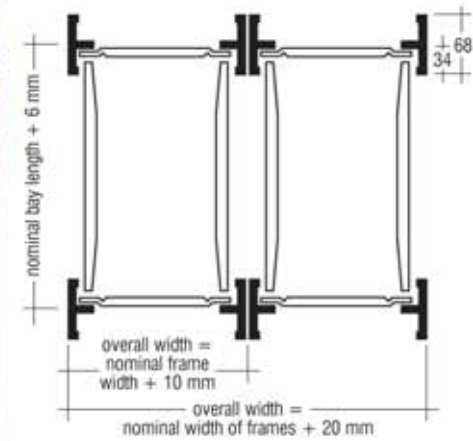

When designing two tier structures, consider the dimensions and details of the sketch shown above. Always refer and adhere to the calculation and safety code summarized on pages 4 and 5.

Max. shelf bay length: 1500 mm
Max. width of walkway: 1200 mm

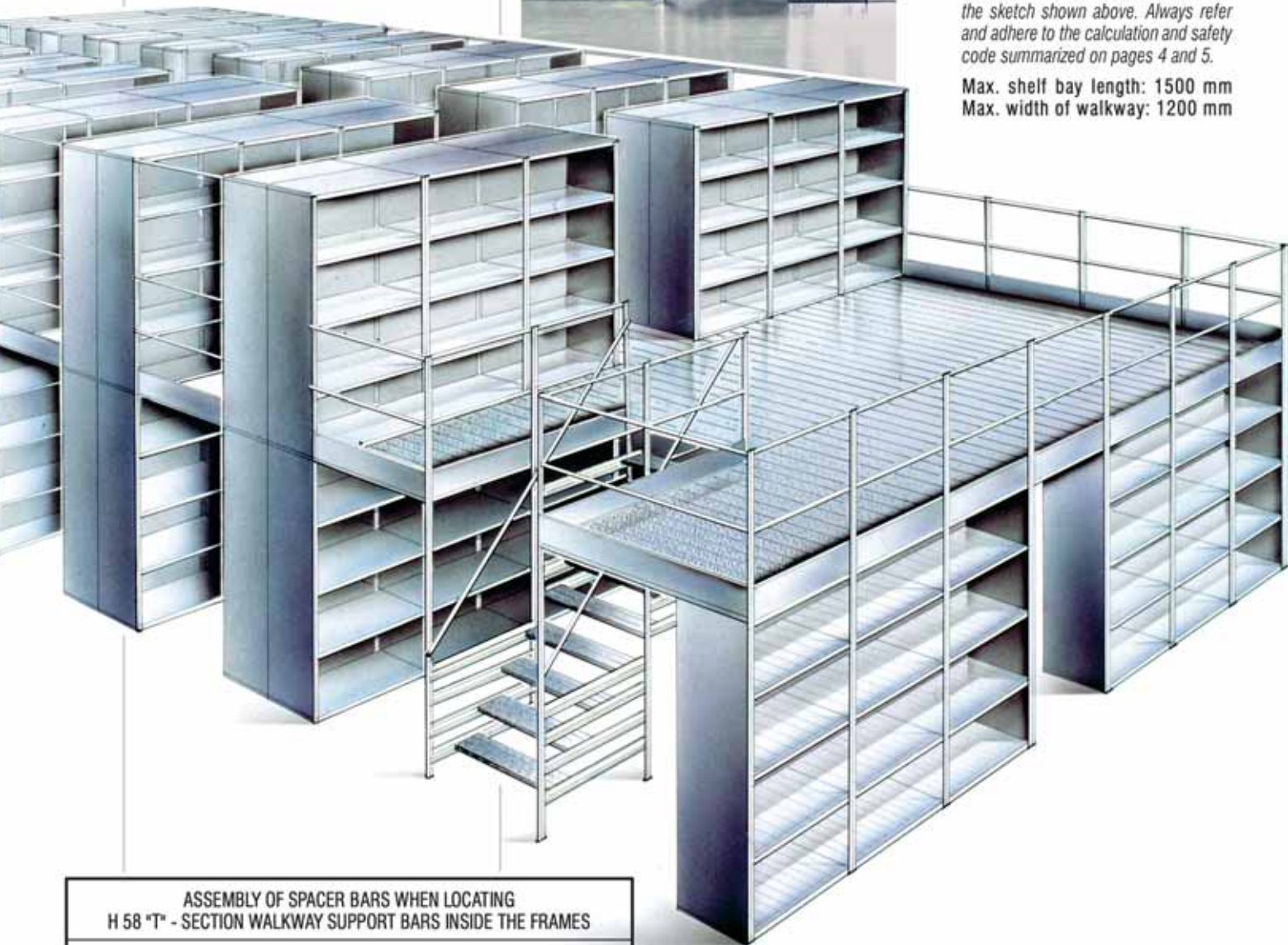

ASSEMBLY OF SPACER BARS WHEN LOCATING H 58 "T" - SECTION WALKWAY SUPPORT BARS INSIDE THE FRAMES

L 900 : NO SPACER BAR

L 1200 : ONE SPACER BAR AT THE CENTRE

L 1500 : ONE SPACER BAR AT THE CENTRE

- NOTE:**
- The spacer bars connecting the "T"-walkway support bars must be ordered in a special length (10 mm narrower than those used to assemble the standard frame).
 - When building staircases, customers should fit one spacer bar under each stair tread.
 - The load bearing capacity of the H58-T-section walkway support bars are stated in the technical handbook.

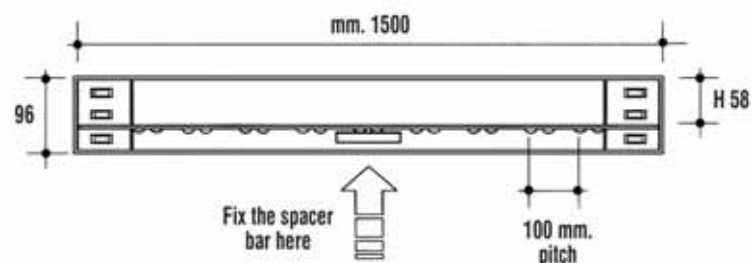

Steel planks

These can be supplied with three different surfaces: ribbed, open and smooth, together with compensation panels and fastening components. The steel planks are inserted into the "T" section supports by levering between the panel and the support (Ref.32). There are two types of steel planks: one for walk-through bays and one for walkways. When ordering, always refer to the length of the respective spacer bar used for building the walkway or the frames.

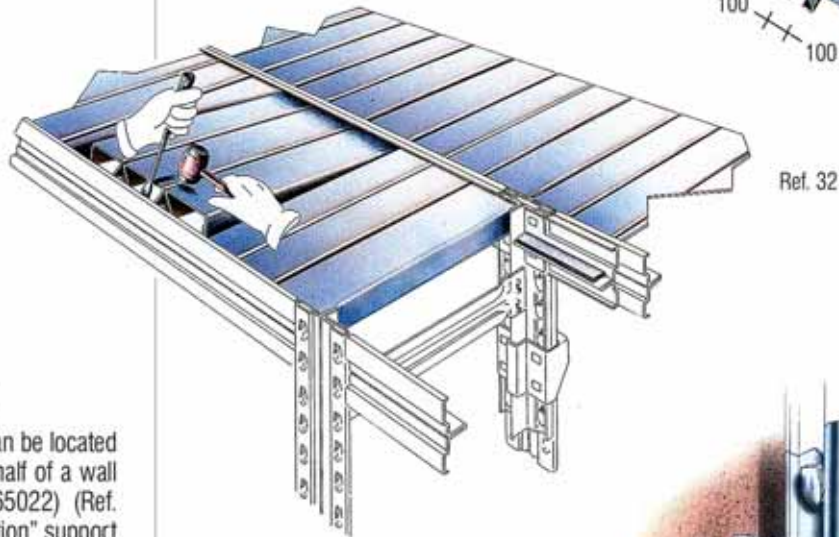
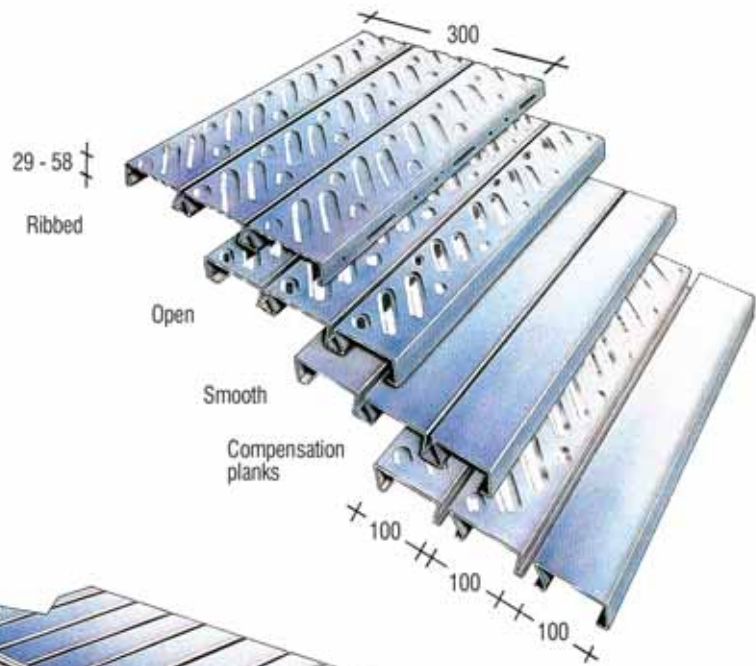

"T-Section" Support Bracket - at 90°

"T-Section" support bars can be located at 90° by assembling one half of a wall fastening bracket (art.nr. 65022) (Ref. 34) and one half of a "T-section" support bracket (art.nr. 67022) (Ref. 33).

Wall fastening brackets are also available, similar to the above, providing a method to fix the frames to a wall for stability (Ref. 34).

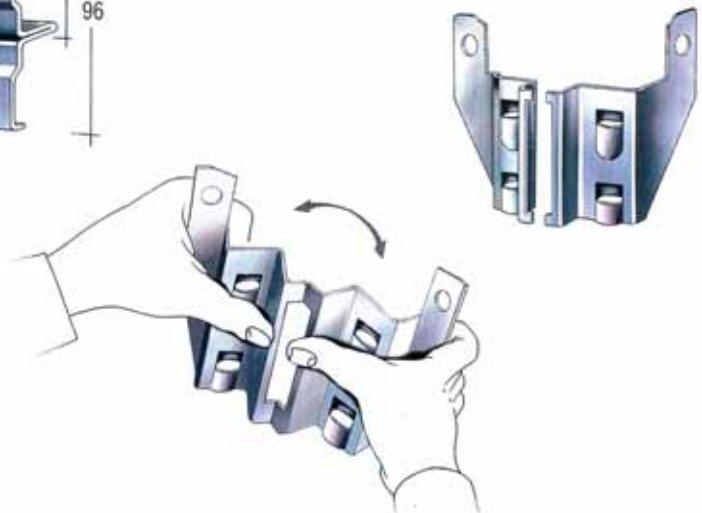
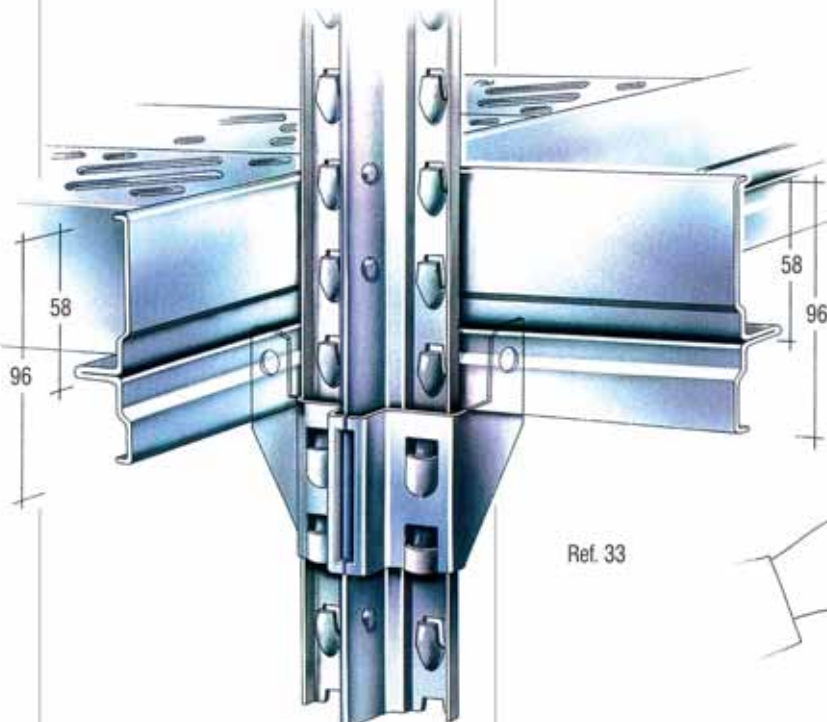
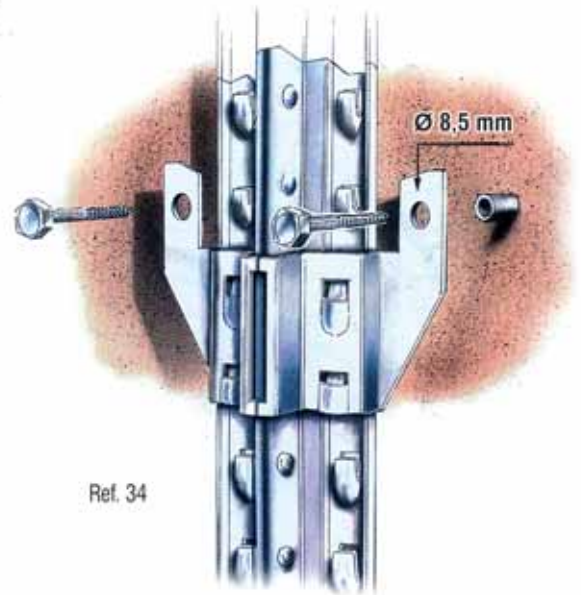

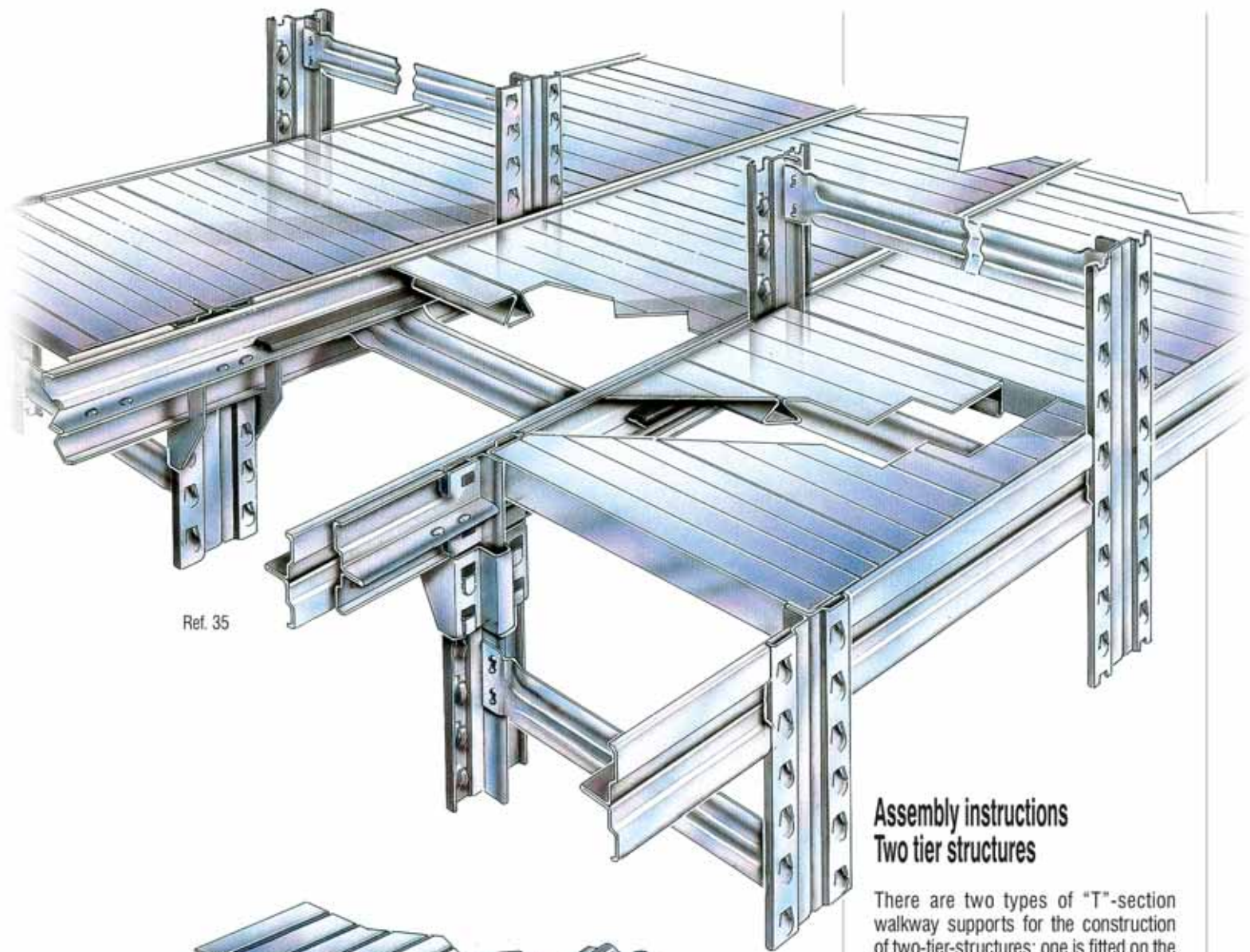

Ref. 35

Assembly instructions Two tier structures

There are two types of "T"-section walkway supports for the construction of two-tier-structures: one is fitted on the outside of the upright by means of support brackets to support walkways between shelf runs, and the other is fitted inside and onto the upright to support walk-through bays, providing continuity of the steel walkway decking (Ref. 38).

The ribs on the "T"-section walkway support beams H58 allow these beams to be connected between them by means of spacer bars being 10 mm narrower than those used to assemble the respective frame (Ref. 35). To reduce noise, a PVC strip is fitted between the steel planks and the "T"-section support bars (Ref. 37). To achieve a correct assembly of the "T"-section support beams within walkways (Art. 67015) these spacer bars must be located under the walkway support beams, at centre distances of 800 mm approximately (Ref. 35/36).

In order to avoid sharp edges, the "T"-section supports should be assembled with an overhang of about 2 cm and finished off with plastic top caps (Ref. 42).

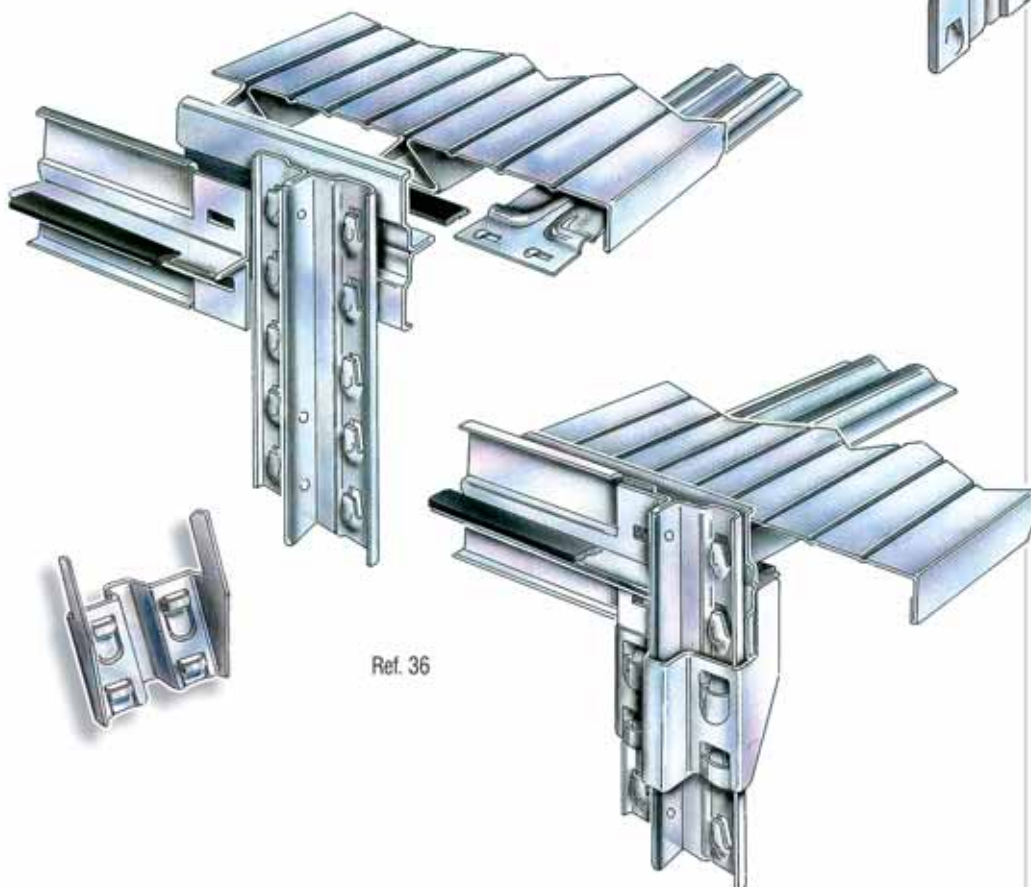

Ref. 36

For fixing back-to-back frames together, use the two-tier support bracket, bending the tongues behind the second upright, as shown on Ref. 37.

When designing two-tier structures, remember that the overall width of every frame and every walkway will be about 10 mm more than the length of the spacer bar used. Also, when calculating the total length of runs, allow for approximately 6 mm of "creep" per bay (see page 26).

When using any other type of flooring, it is important to note that the floor panel itself will be 4 mm narrower than the spacer bars used to assemble the walkways and respectively 12 mm narrower than the spacer bars used to assemble walk-through-bays.

In all cases, only SUPER 3 components should be used when designing two-tier structures.

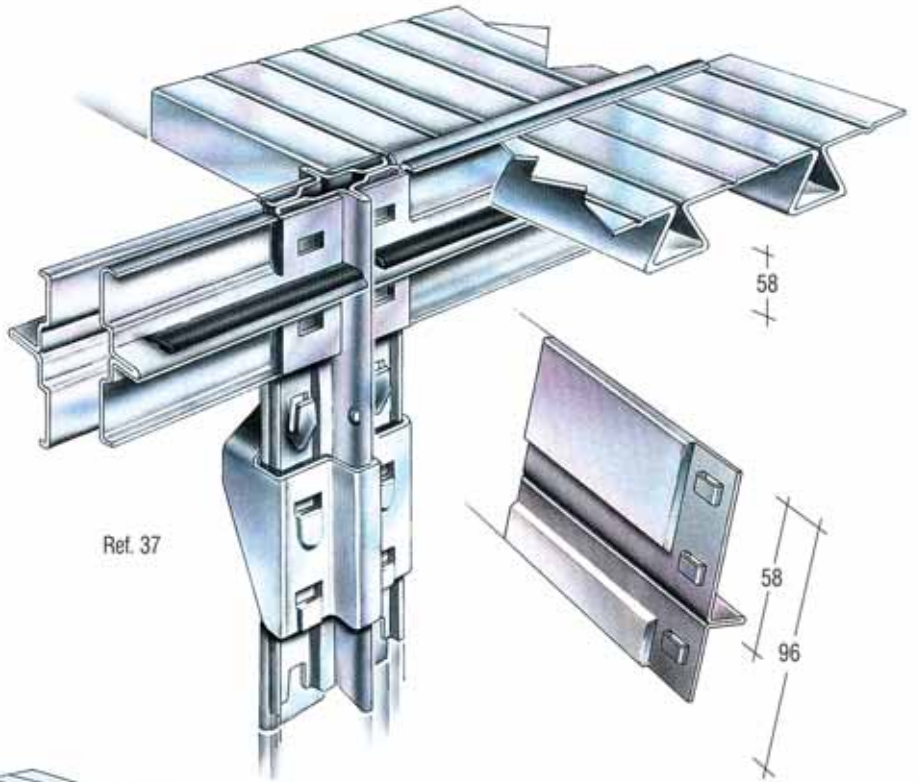

Ref. 37

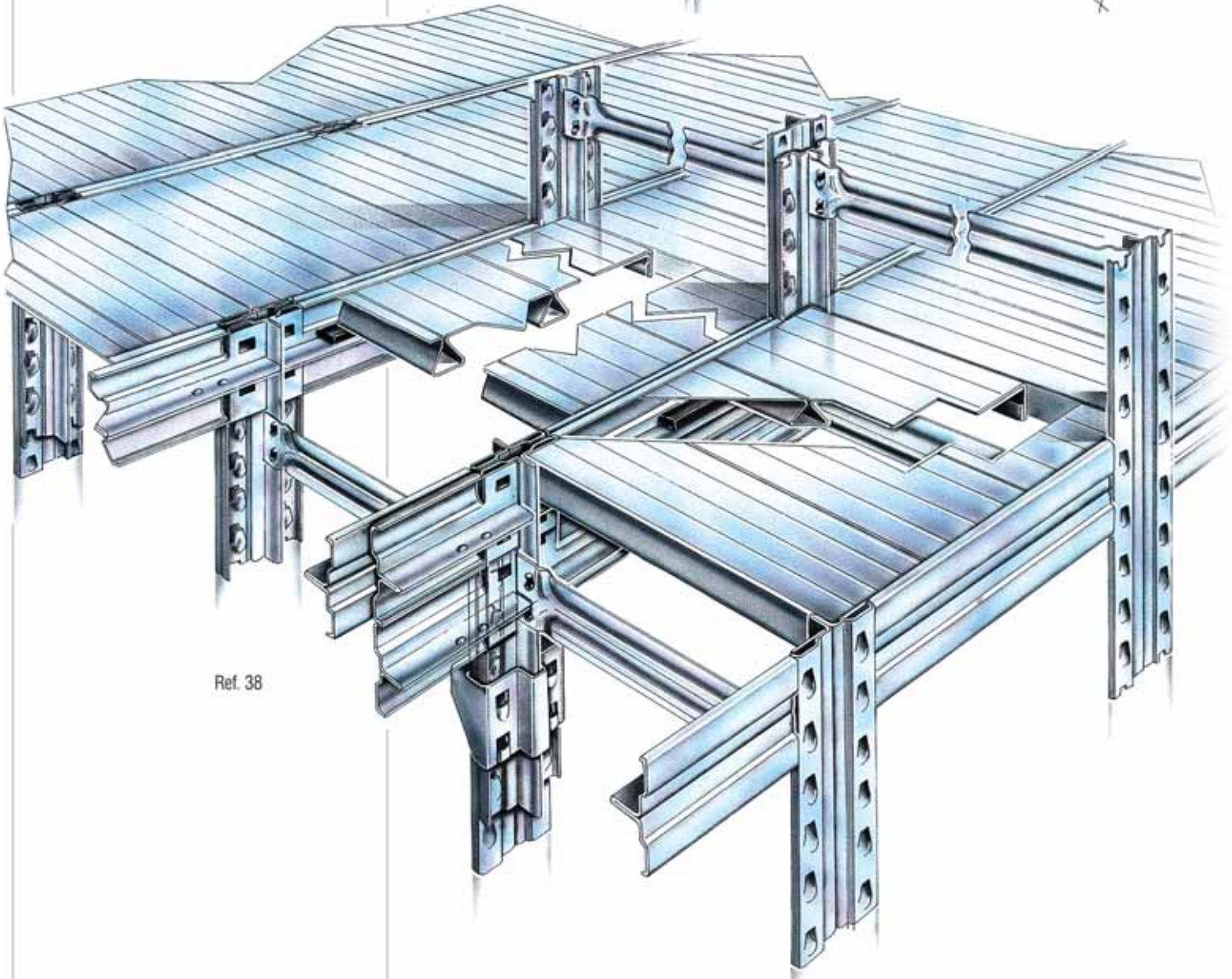

Ref. 38

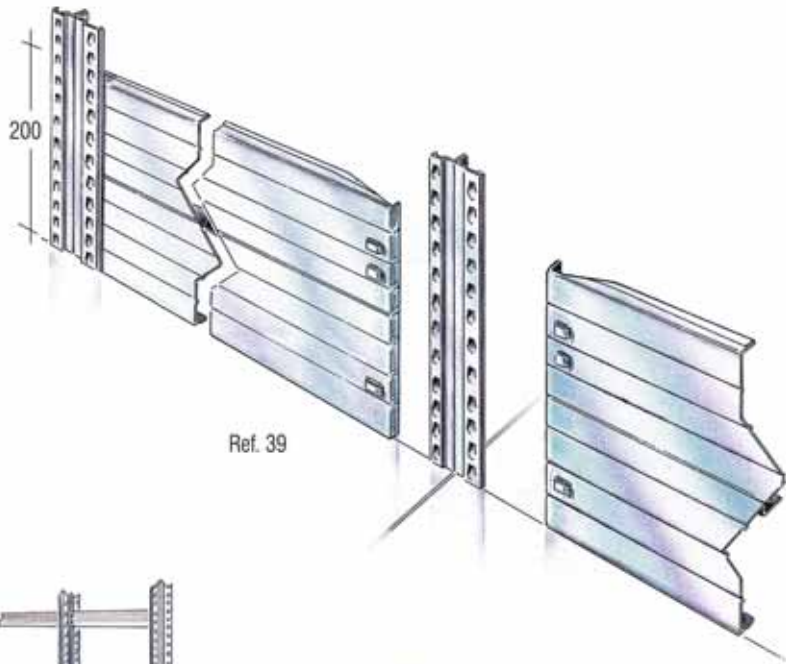

Ref. 39

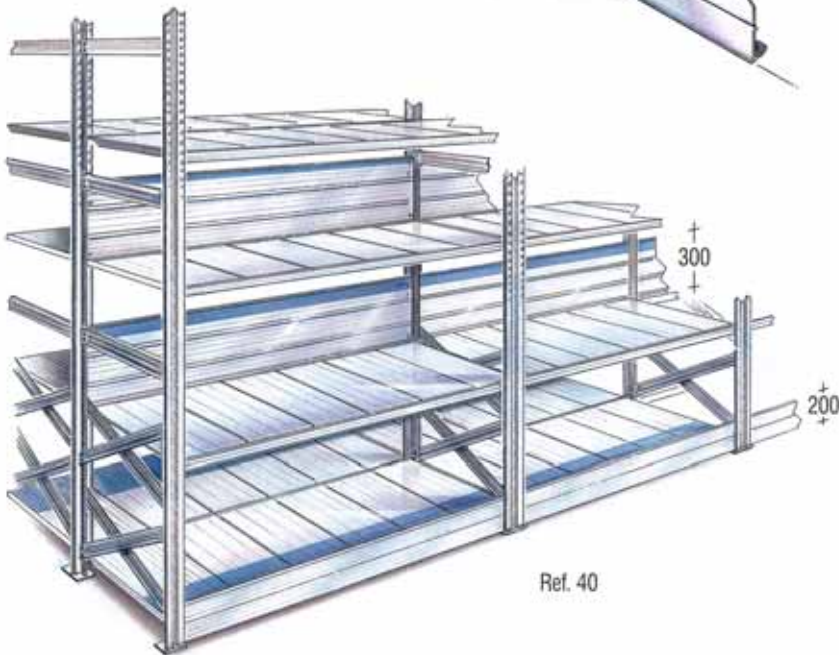

Ref. 40

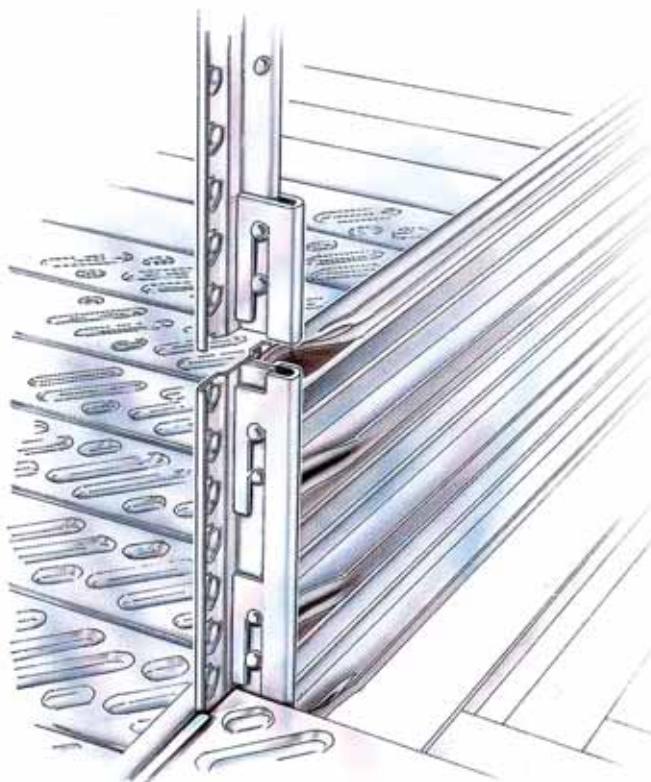

Ref. 50

Kickboards

Three different types of kickboards are available: for use in the direction of the beams, at the end of a run within uprights, or for walkway ends.

Kickboards are made from two oval shaped tubes (the same items used to build the handrails) fixed to the uprights and finished off with a metal sheet element located onto the oval shaped tubes by self tapping screws. For correct ordering of these items and dimensions, please see instructions on page 48 of the technical brochure. The use of beam retaining clips is mandatory.



In the direction of the beams, shelf boards are available in two different heights, 200 or 300 mm (article n° 64016-64040).

These items have flanged ends with slots to be located onto the uprights (Ref. 39).

Upright reinforcement

Uprights that are used as newel posts for handrail should always be fitted with the reinforcing brackets shown (Ref.50).

Hand rails

Hand rails and knee rails are made from oval shaped beams. For correct ordering of these items, please see instructions on page 48 of this brochure.

The use of beam retaining clips and upright tops caps is mandatory.

Handrails on two-tier structures can also be built with "U"-section profiles assembled in conjunction with special P.V.C. supports.

These supports can also be used to finish off the handrails at their ends (Ref. 47-48).

Staircase handrails

Thanks to the handrail support bracket (Ref. 45), the staircase handrail can be easily located on the uprights, without any need to drill holes.

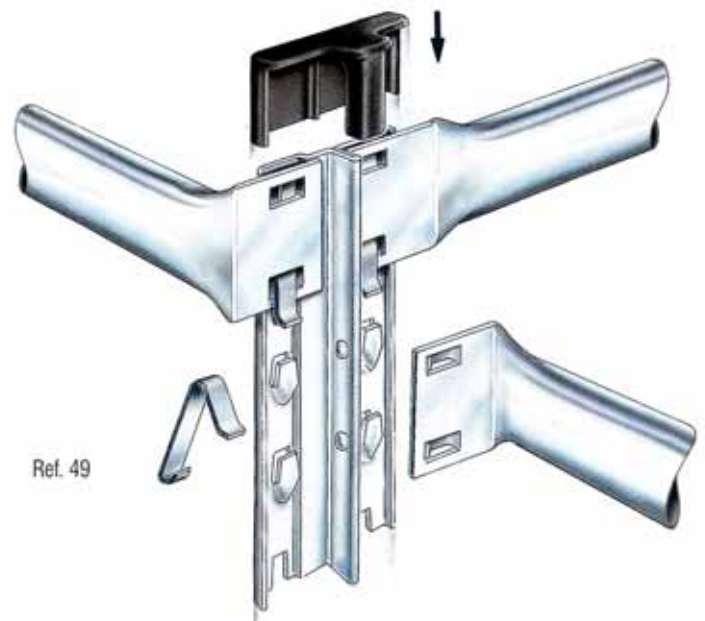
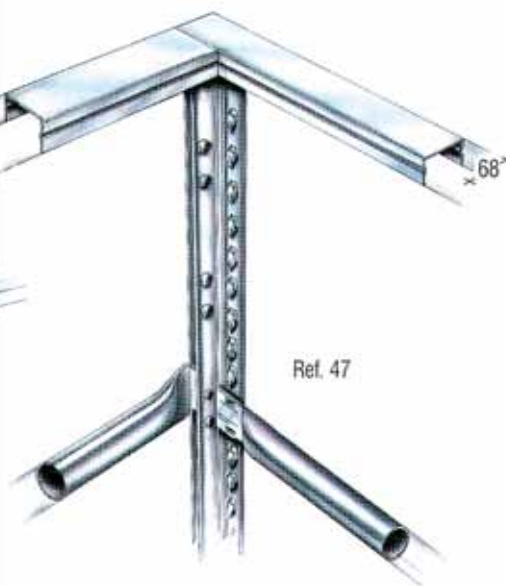
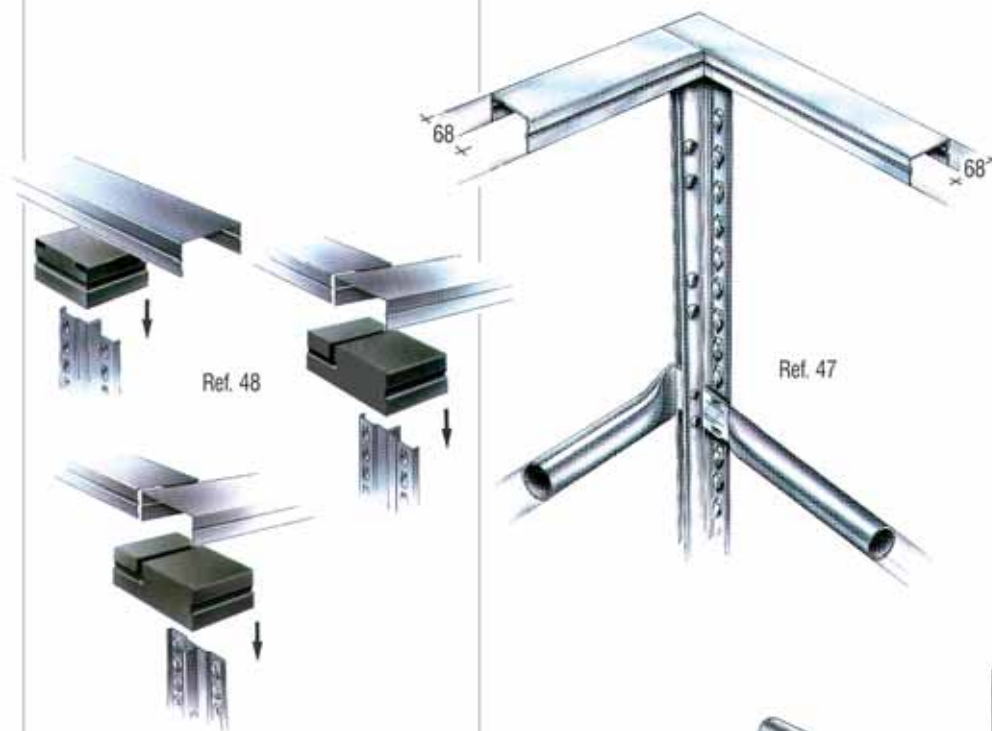
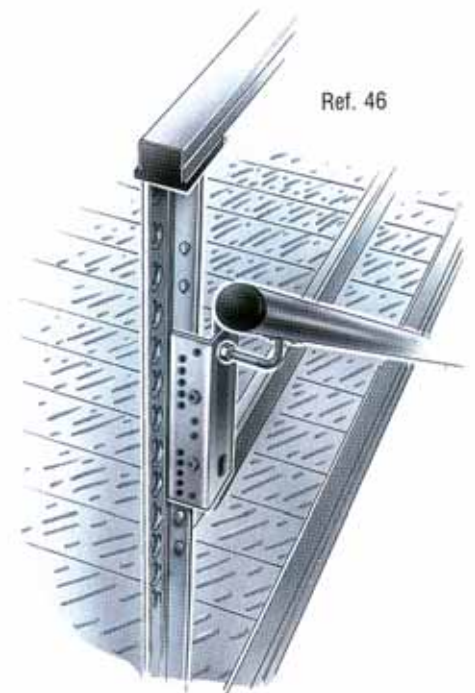
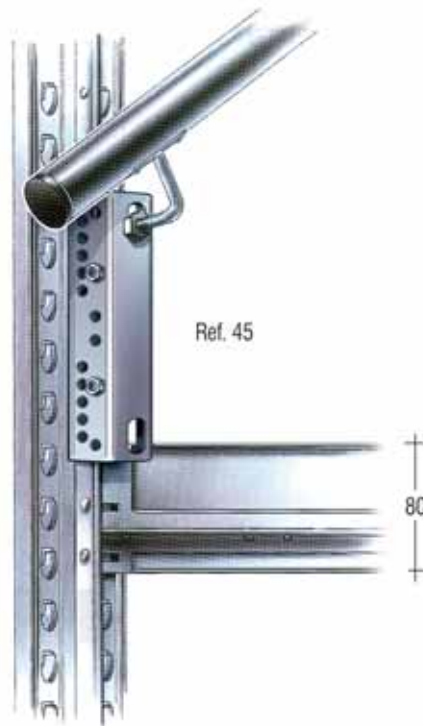







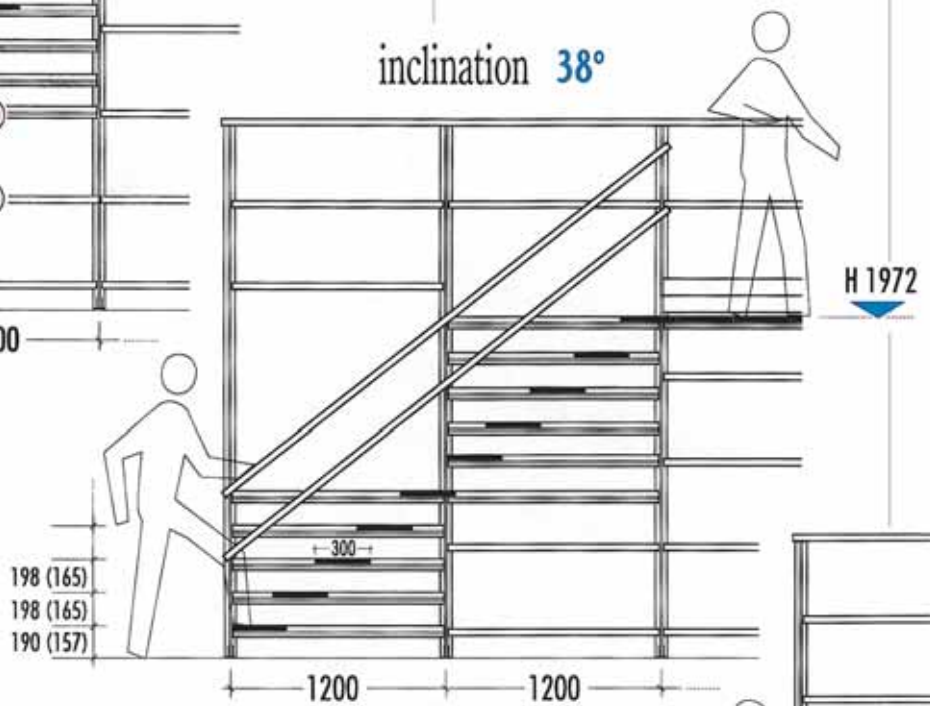
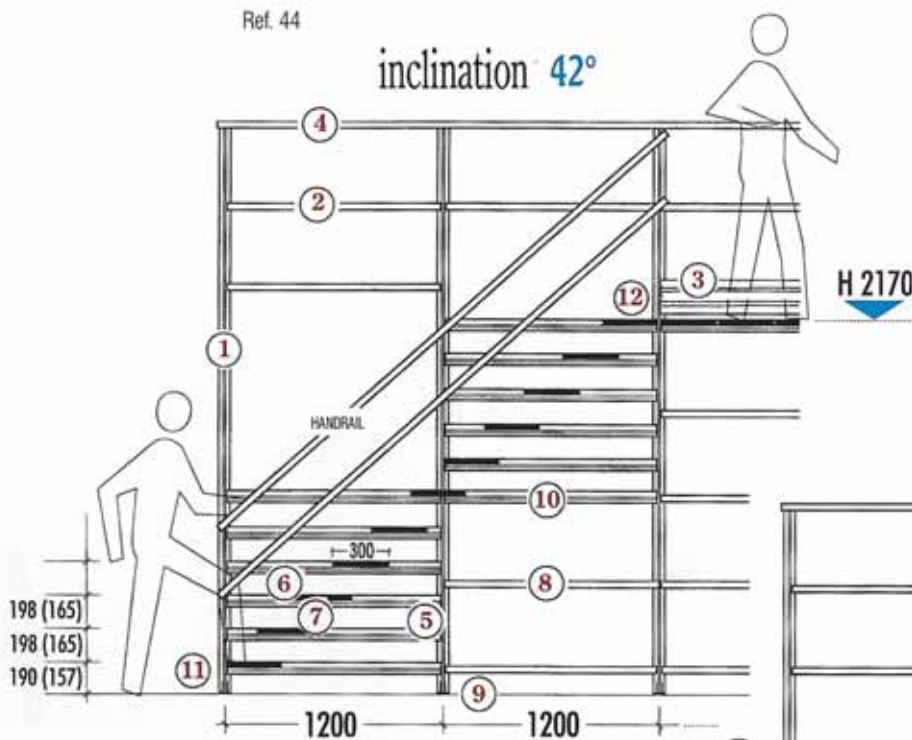

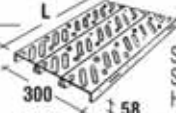

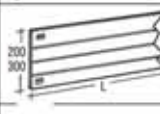
STAIRCASES

These can be built using standard components. The length of the stair treads is specified as a steel plank with a dimension between uprights. The stair treads will be fixed with two special clips (Art. n° 69829).

To improve the stability and load bearing capacity of the staircase, the "T" section beams H58 should be assembled by fitting one spacer bar under each stair tread. These spacer bars will be 10 mm narrower than those used to assemble normal standard frames.



1		REINFORCED UPRIGHT	7		STAIR TREAD / STEEL PLANK H58 - 15/10
2		TUBULAR BEAM	8		BEAM H 47
3		SHELF BOARD	9		HEAVY DUTY METAL BASE PLATE
4		"U" SECTION HANDRAIL	10		T-SECTION-WALKWAY SUPPORT BAR
5		BRACKET/CLIP	11		LOCKING FRAME SPACER BAR
6		SPACER BAR TO BE LOCATED UNDER EACH STAIR TREAD	12		REINFORCING BRACKET FOR UPRIGHTS

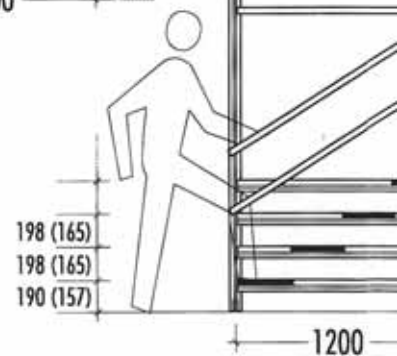

The reinforced upright version (Art.nr. 99230 = SUPER-3 upright, welded with a "U"-profile on its front face) must be used either side of the staircase, i.e. for uprights that are not supported by frame bracing.



Inclination 32°

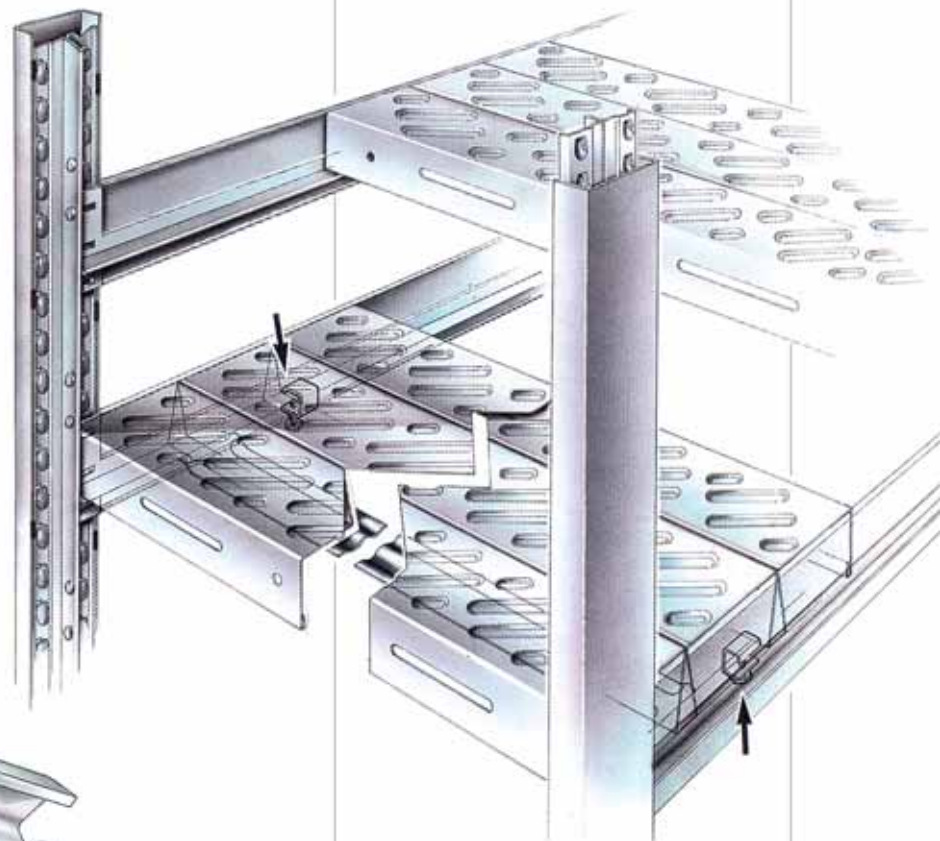
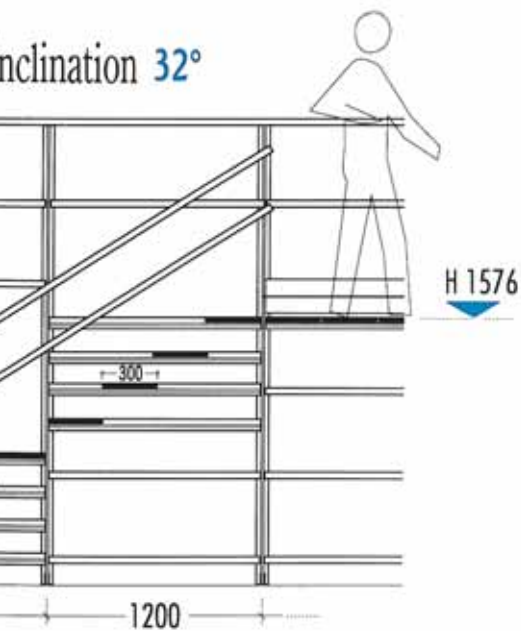

It is recommended to continue with the regular frame bracing pattern within these frames, as soon as possible.



Mobile Shelving

Thanks to its attractive high-tech design, SUPER 1-2-3 is also a highly suitable and cost effective mobile shelving solution, that can be applied to all environments.



Mobile Ladders

Mobile Ladders are available in 2.5 and 3 meter height and can be supplied with guide rails and curves to adapt them to any environment (Ref. 56).



Ref. 56

Steel planking

"T"-sections can be used as support beams for the steel planking (Ref.55). Floors of any dimension can be built in conjunction with "H" joints and "U" section channels.

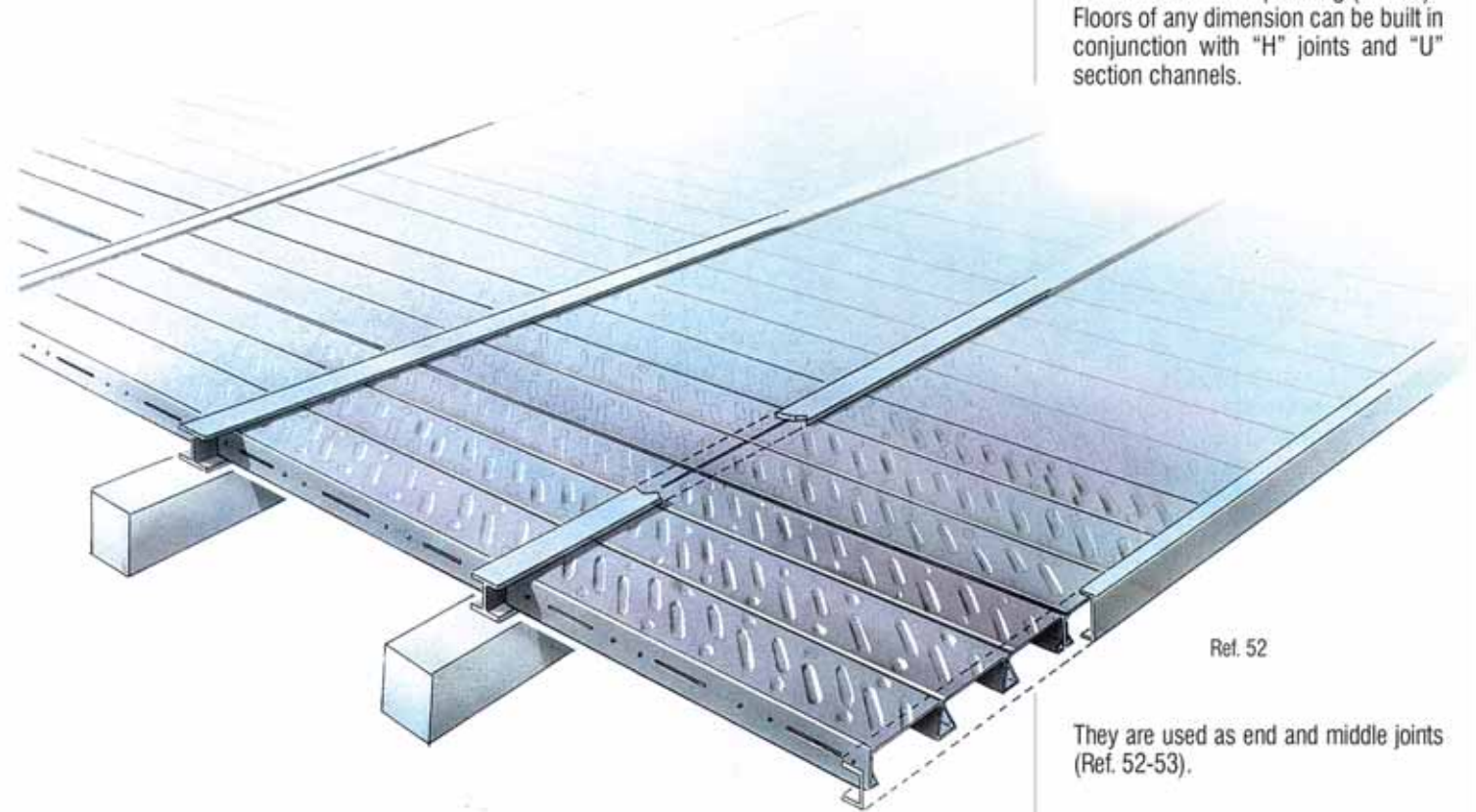

Ref. 52

They are used as end and middle joints (Ref. 52-53).

The 70-mm-section walkway beam (art. 99253B) provides an alternative solution to the use of the "T"-section support bars. It enables the steel planks to be laid in length direction along the walkways (Ref. 57).

Ref. 57

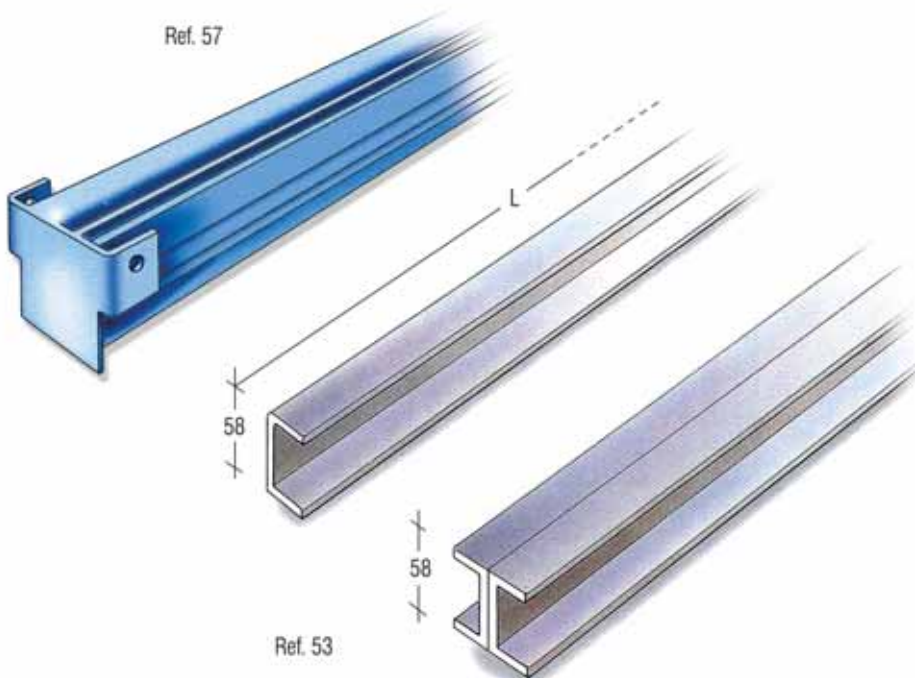

The "T"-section supports are fitted back-to-back. One is fitted on the outside of the upright by means of support brackets, and the other is fitted inside and onto the upright.

The steel planks are laid over the top and are fixed down by means of the special clamp (Ref.54).

When joining the planks in a transverse direction the 6x20 mm bolt should be used in the appropriate holes.

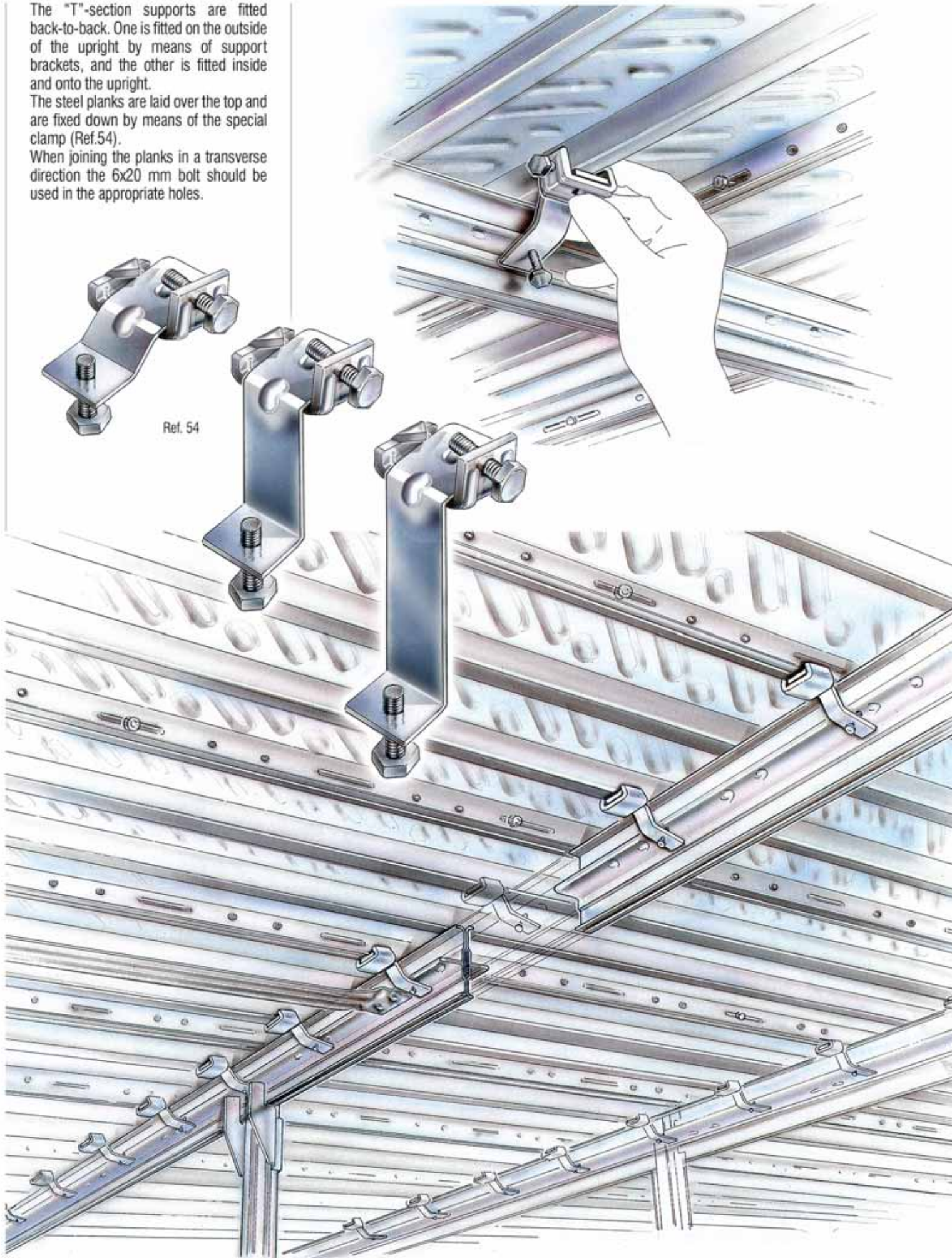

Ref. 54

Ref. 55

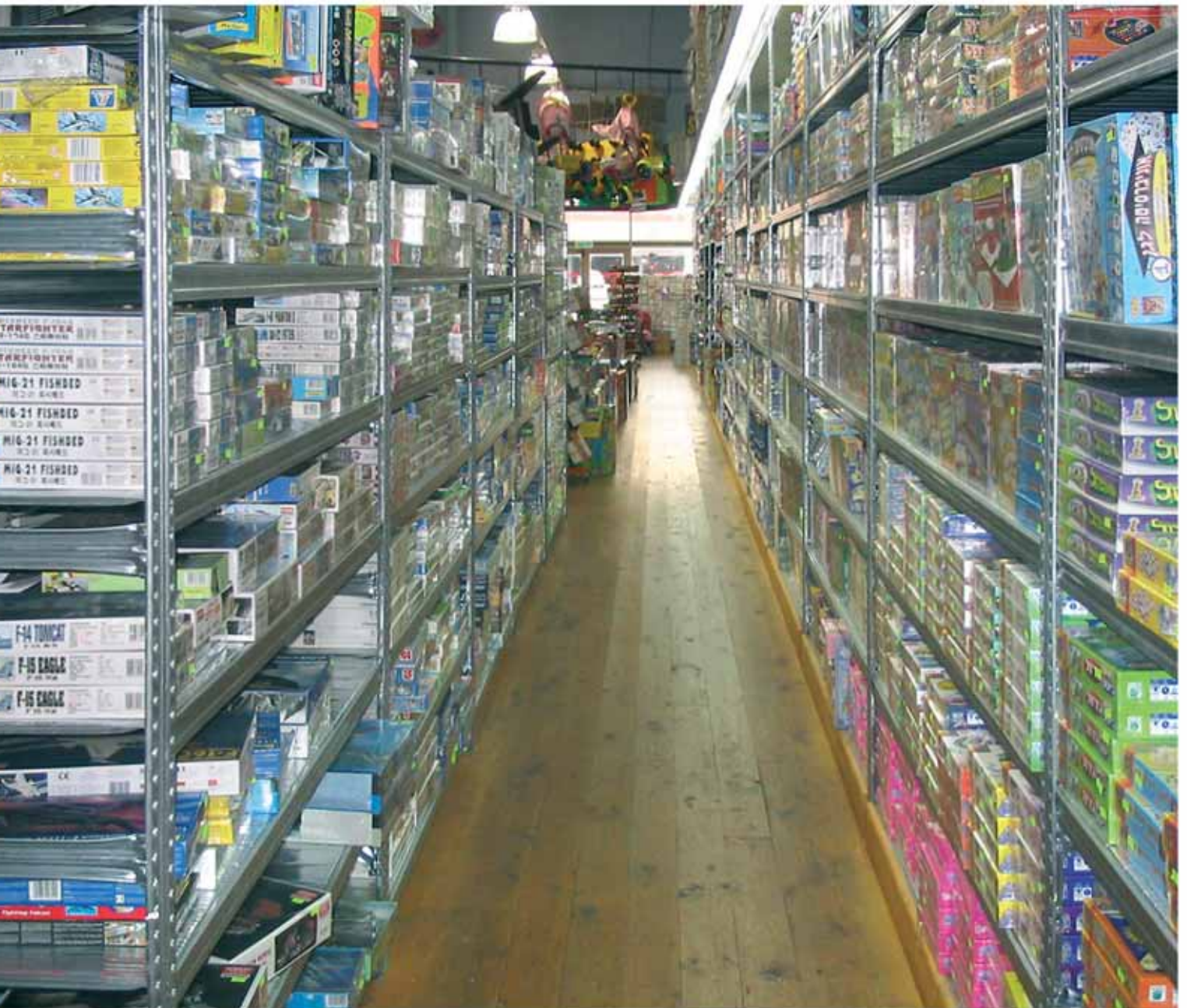

SIMPLY SUPER - DO-IT-YOURSELF - PATENTED BOLTLESS SHELVING KITS

"SIMPLY SUPER" are do-it-yourself shelving kits, conceived for easy use within the domestic environment.

SIMPLY SUPER is available in two different heights - 1840 and 1576 mm - with 5 or 4 shelf levels in height, respectively.

Starter bays can be easily integrated with add-on-bays. All of them in 900 mm width and 400 mm depth. Shelves can be regulated in height at a 33 mm pitch.



SIMPLY SUPER is made from prime quality high tensile steel, certified according to EN 10204 3.1B.

BULL SERIES - PLASTIC BINS - Ref. page 19

COLOURS	BULL 1	BULL 2	BULL 3	BULL 4 BULL 4/D	BULL 5	BULL 6 BULL 6/D	BULL 7 BULL 7/D
green ●	●	●	●	●	●	●	●
blue ●	●	●	●	●	●		
red ●	●	●	●	●	●		
yellow ●	●	●	●	●	●		
grey ●	●	●	●	●	●		

Open fronted bins with very strong structure. Easily to be placed one upon another. Large front label holder. Made from high density polyethylene, for use in environments ranging from -40°C up to +80°C. Fracture and breakage proof. Resistant to acids, oils, solvents and detergents. Ergonomic line with comfortable handles for lifting. Base completely flat and anti-skid. Full length return to clip to louvred panels. Brilliant colours and agreeable design.

BULL 1



L. 105 x D. 88/70 x H. 54
Package of 100 pcs.

BULL 2



L. 105 x D. 167/140 x H. 82
Package of 48 pcs.

BULL 3



L. 144 x D. 237/190 x H. 123
Package of 38 pcs.

BULL 4



L. 205 x D. 345/270 x H. 164
Package of 24 pcs.

BULL 5



L. 298 x D. 485/400 x H. 189
Package of 12 pcs.

BULL 4/D



L. 406 x D. 345/270 x H. 164
can be equipped with 1, 2 or 3 mobile dividers
Package of 8 pcs.

**BULL 6/D
BULL 6**



L. 372 x D. 600/460 x H. 250
Package of 4 pcs.

**BULL 7
BULL 7/D**



L. 442 x D. 700/540 x H. 300
Package of 4 pcs.

● = available without fixed divider

◆ = available with fixed divider



* = horizontal connection element (only for BULL 6 - 6/D and BULL 7 - 7/D)

METALSISTEM



FEM section X

SUPER 1 / 2 / 3



METALSISTEM
SISTEMI E STRUTTURE PER IL MAGAZZINO

METALSISTEM S.p.A.
38068 Rovereto (Tn) - Viale dell'Industria, 2 - Italy
Tel. 0039 0464 303030 - Fax 0039 0464 303031
info@metalsistem.com - www.metalsistem.com

NR. EDIZIONE 03
DATA EDIZIONE 12/2008
NR. REVISIONE 00
DATA REVISIONE 00
DATA STAMPA 01/2005

411C ROVERETO - ROVERETO